

GOT5152T-834

15" XGA TFT Fanless Touch Panel Computer with Intel® Celeron® Processor J1900



Features

- 15" XGA TFT LCD display with LED backlight
- Fanless cooling system with Intel® Celeron® processor J1900
- WLAN module and internal antenna
- 2 GbE LAN, 4 USB and 3 COM
- PCI Express Mini Card for easy expansion
- Supports panel mount/wall mount/VESA arm
- Supports RFID (optional)
- Plastic and IP65-rated front bezel

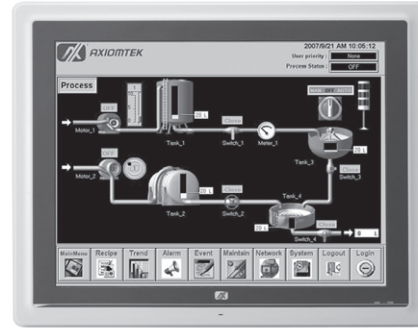

▲ Side view



▲ CFAST™ slot with protective cover

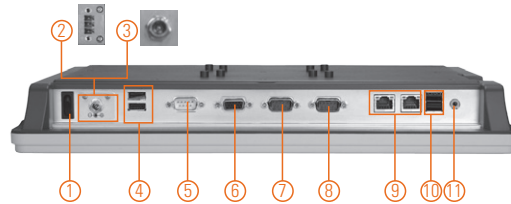

1. Power switch (ATX)
2. Terminal block for DC power input or
3. Screw conn. w/ AC power adapter
4. USB 2.0 x 2
5. COM 3 (RS-232/422/485)
6. VGA
7. COM 1 (RS-232/422/485)
8. COM 2 (RS-232/422/485)
9. Ethernet x 2
10. USB 3.0 x 2
11. Audio (Line-out)



Introduction

Axiomtek GOT5152-834 utilizes the fanless technology with Intel® J1900 quad cores CPU. Running Windows or Linux, this panel system provides great performance for many commercial and industrial applications. This slim design incorporates a 15" 420 nits LCD display providing a bright XGA (1024 x 768) touch screen. Wireless communications is supported with a built-in antenna within the bezel, ready for your choice of optional PCI Express Mini Card. There are two choices for powering the unit, Class B that includes an external AC to DC power brick with screw-on power connector, or Class A with no power brick, providing a Phoenix style DC connector (9 to 36 VDC). Using an all industrial-grade IP-65 rated design, weighted 7 to 11 lbs (depending on configuration), this 15" fanless touch panel computer provides an attractive cost, low power, high performance, reliable quality, slim size and low weight, all new for more demanding applications.

Super Slim & Ultra Light Weight Design

The GOT5152T-834 is a super slim touch panel computer for space-limited environment with its thickness of 54.6 mm and weight of 3.2 kg only, which make it installed everywhere.

Built-in Internal WLAN Antenna

The GOT5152T-834 provides 2 PCI Express Mini Card slots and a built-in WLAN antenna for wireless network connections. By simply plugging in the wireless LAN cards, customers can use the GOT5152T-834 in a wireless LAN/GPRS/GSM/4G environments.

Aluminum Back Chassis with Excellent Thermal Solution

With Axiomtek's patent for plastic plus aluminum mechanism design, the GOT5152T-834 can dissipate the heat easily and keep the system operation stable.

Specifications

Front Bezel	IP65, NEMA 4 rugged protection, plastic front bezel
LCD Panel	Display Type 15" XGA TFT LCD with LED backlight
	Brightness (cd/m ²) 420 nits
	Resolution 1024 x 768
	Viewing Angel (H/V) 160°/140°
Main System	CPU Intel® Celeron® processor J1900 4 cores
	System Memory 1 x 204-pin DDR3L-1333 MHz SO-DIMM, up to 8GB
	BIOS AMI UEFI BIOS
	Storage 1 x 2.5" 7/9.5mm SATA HDD 1 x CFAST™ or mSATA
	Watchdog Timer 255 levels, 0 to 255 sec.
	Onboard Graphics Integrated in Intel® GFX

Specifications

I/O Connector	3 x RS-232/422/485 (default RS-232, COM 1/2/3) 1 x VGA 1 x Audio (Line-out) 2 x USB 2.0 2 x USB 3.0 2 x 10/100/1000 Mbps Ethernet (Intel® i210IT)
TPM	N/A
Expansion Interface	1 x full-size PCI Express Mini Card slot with mSATA 1 x full-size PCI Express Mini Card slot with SIM
Touchscreen	Resistive type
Power Input	1. DC version: 9 to 36 VDC with over-current protection fuse 2. AC version: 100 to 240 V AC-DC, 60W power adapter
Power Consumption	36 W
Dimensions	387.9 mm (15.27") (W) x 54.6 mm (2.14") (D) x 307.7 mm (12.11") (H)
Packing Dimensions	510 mm (20.08") (W) x 105 mm (4.13") (D) x 385 mm (15.16") (H)
Weight (net/gross)	3.2 kg (7.05 lb)/5.1 kg (11.24 lb)
Environment	Operating temperature: 0°C to +50°C (+32°F to +122°F) (with W.T. DRAM/HDD in airflow condition) 0°C to +45°C (+32°F to +113°F) (with W.T. DRAM/HDD) Relative humidity: 20% to 90% @ +40°C; non-condensing Operation vibration: 2G, 5 to 500 Hz, random for CFast™
Certificate	CE

* Specification and certifications are based on options and may vary.

** W.T.: Wide Temperature. All W.T. supported products have to be sorted by Axiomtek.

Packing List

- 1 x GOT5152T-834
- 1 x Driver CD
- 1 x Adapter (GOT5152T-834-J)
- 1 x Panel mount kit
- 1 x Wall mount kit
- 1 x Phoenix connector (GOT5152T-834 DC)

Dimensions

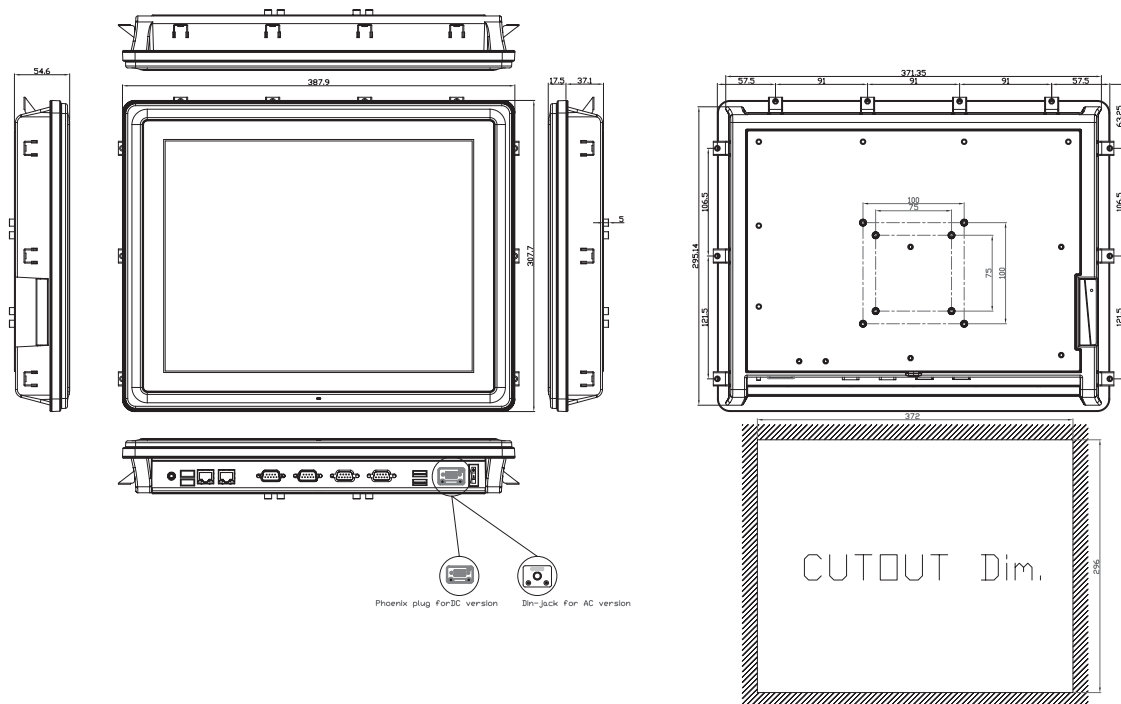

Ordering Information

GOT5152T-834-J	15" XGA fanless touch panel computer with Intel® Celeron® processor J1900, 5-wire resistive touch screen, AC-DC 60W power adapter (screw type connector) and EMI class B
GOT5152T-834-DC	15" XGA fanless touch panel computer with Intel® Celeron® processor J1900, 5-wire resistive touch screen, and 9 to 36 VDC power input (terminal block connector)

Optional

Wi-Fi + Bluetooth kit	
Speaker kit	
E226171106	Stand kit
881251203A0E	RFID kit

* Specification and certifications are based on options and may vary.

Optional EOS Installation

WES 7	
WE8S	
Windows 10 IoT Enterprise	

Optional OS Installation

Windows® 7	
Windows® 8.1	
Windows® 10	



▲ Desktop stand



▲ AC power adapter (GOT5152T-834-J)