

# Power Module

## GT-7xxx User Manual



REV 1.01

DOCUMENT CHANGE SUMMARY				
REV.	PAGE	REMARKS	DATE	EDITOR
1.00	New Document		2018/07/30	YE JEON
1.01	6,7 9,12,16,19,22,25,35 12,16,19,22,25 15 27-34	Certificates, Power Module List Updated Revision related to UL certification Module Weight System/Field Power LED Noise Filter Modules Added	2020/07/13	YE JEON

## Contents

<b>1. Important Notes</b> .....	5
<b>1.1. Safety Instruction</b> .....	6
<b>1.1.1. Symbols</b> .....	6
<b>1.1.2. Safety Notes</b> .....	6
<b>1.1.3. Certification</b> .....	6
<b>2. Power Module List</b> .....	7
<b>3. Specification</b> .....	8
<b>3.1. GT-7408</b> .....	8
<b>3.1.1. Wiring Diagram</b> .....	8
<b>3.1.2. LED Indicator</b> .....	9
<b>3.1.3. Status LED</b> .....	9
<b>3.1.4. Specification</b> .....	9
<b>3.1.5. Example</b> .....	10
<b>3.2. GT-7508</b> .....	11
<b>3.2.1. Wiring Diagram</b> .....	11
<b>3.2.2. LED Indicator</b> .....	12
<b>3.2.3. Status LED</b> .....	12
<b>3.2.4. Specification</b> .....	12
<b>3.2.5. Example</b> .....	13
<b>3.3. GT-7511</b> .....	14
<b>3.3.1. Wiring Diagram</b> .....	14
<b>3.3.2. LED Indicator</b> .....	15
<b>3.3.3. System/Field Power LED</b> .....	15
<b>3.3.4. Status LED</b> .....	15
<b>3.3.5. Specification</b> .....	16
<b>3.3.6. Example</b> .....	17
<b>3.4. GT-7518</b> .....	18
<b>3.4.1. Wiring Diagram</b> .....	18
<b>3.4.2. LED Indicator</b> .....	19
<b>3.4.3. Status LED</b> .....	19

---

3.4.4. Specification .....	19
3.4.5. Example .....	20
3.5. GT-7588 .....	21
3.5.1. Wiring Diagram.....	21
3.5.2. LED Indicator.....	22
3.5.3. Status LED .....	22
3.5.4. Specification.....	22
3.5.5. Example .....	23
3.6. GT-7641 .....	24
3.6.1. Wiring Diagram.....	24
3.6.2. LED Indicator.....	25
3.5.3. Status LED .....	25
3.5.4. Specification.....	25
3.5.5. Example .....	26
4. Environment Specification .....	35
5. Dimension .....	36
5.1. GT-7XXX .....	36
6. Mounting.....	37
6.1. I/O Inserting and Removing Devices.....	37
6.2. RTB (Removable Terminal Block).....	38
7. G-Bus Pin Description .....	39
8. Trouble Shooting .....	40

## 1. Important Notes

Solid state equipment has operational characteristics differing from those of electromechanical equipment.

Safety Guidelines for the Application, Installation and Maintenance of Solid State Controls describes some important differences between solid state equipment and hard-wired electromechanical devices.

Because of this difference, and also because of the wide variety of uses for solid state equipment, all persons responsible for applying this equipment must satisfy themselves that each intended application of this equipment is acceptable.

In no event will CREVIS be responsible or liable for indirect or consequential damages resulting from the use or application of this equipment.

The examples and diagrams in this manual are included solely for illustrative purposes. Because of the many variables and requirements associated with any particular installation, CREVIS cannot assume responsibility or liability for actual use based on the examples and diagrams.

### Warning!



- ✓ **If you don't follow the directions, it could cause a personal injury, damage to the equipment or explosion**
- Do not assemble the products and wire with power applied to the system. Else it may cause an electric arc, which can result into unexpected and potentially dangerous action by field devices. Arching is explosion risk in hazardous locations. Be sure that the area is non-hazardous or remove system power appropriately before assembling or wiring the modules.
- Do not touch any terminal blocks or IO modules when system is running. Else it may cause the unit to an electric shock or malfunction.
- Keep away from the strange metallic materials not related to the unit and wiring works should be controlled by the electric expert engineer. Else it may cause the unit to a fire, electric shock or malfunction

### Caution!

- ✓ **If you disobey the instructions, there may be possibility of personal injury, damage to equipment or explosion. Please follow below Instructions.**
- Check the rated voltage and terminal array before wiring. Avoid the circumstances over 50°C of temperature. Avoid placing it directly in the sunlight.
- Avoid the place under circumstances over 85% of humidity.
- Do not place Modules near by the inflammable material. Else it may cause a fire.
- Do not permit any vibration approaching it directly.
- Go through module specification carefully, ensure inputs, output connections are made with the specifications. Use standard cables for wiring.
- Use Product under pollution degree 2 environment.

## 1.1. Safety Instruction

### 1.1.1. Symbols

<p><b>DANGER</b></p> 	<p>Identifies information about practices or circumstances that can cause an explosion in a hazardous environment, which may lead to personal injury or death property damage, or economic loss</p>
<p><b>IMPORTANT</b></p>	<p>Identifies information that is critical for successful application and understanding of the product</p>
<p><b>ATTENTION</b></p> 	<p>Identifies information about practices or circumstances that can lead to personal injury, property damage, or economic loss.          Attentions help you to identify a hazard, avoid a hazard, and recognize the consequences</p>

### 1.1.2. Safety Notes

<p><b>DANGER</b></p> 	<p>The modules are equipped with electronic components that may be destroyed by electrostatic discharge. When handling the modules, ensure that the environment (persons, workplace and packing) is well grounded. Avoid touching conductive components, G-Bus Pin.</p>
--	---

### 1.1.3. Certification

c-UL-us UL Listed Industrial Control Equipment, certified for U.S. and Canada

See UL File E235505

CE Certificate

EN 61000-6-2; Industrial Immunity

EN 61000-6-4; Industrial Emissions

FCC, Reach, RoHS (EU, CHINA)

## 2. Power Module List

GT-Number	Description	ID (hex)	Production Status
GT-7408	Potential Distributor, 8 CHs, Shield, 10 RTB, ID Type	7408	Active
GT-7508	Potential Distributor, 8 CHs, 0Vdc, 10 RTB, ID Type	7508	Active
GT-7511	Expansion Power, System/Field Power, Input 24Vdc, Output 5Vdc, 1A, 10 RTB, ID Type	7511	Active
GT-7518	Potential Distributor, 10 CHs, 24Vdc, 10 RTB, ID Type	7518	Active
GT-7588	Potential Distributor, 5 CHs, 24Vdc / 5 CHs, 0Vdc, 10 RTB, ID Type	7588	Active
GT-7641	Field Power Distribution 5~48(Vdc), 120~240(Vac) ID Type	7641	Active
GT-7151	Noise Filter Module, 18RTB, None ID Type	7151	Active
GT-7851	Noise Filter Module, 18RTB, ID Type	7851	Active

### 3. Specification

#### 3.1. GT-7408

##### 3.1.1. Wiring Diagram

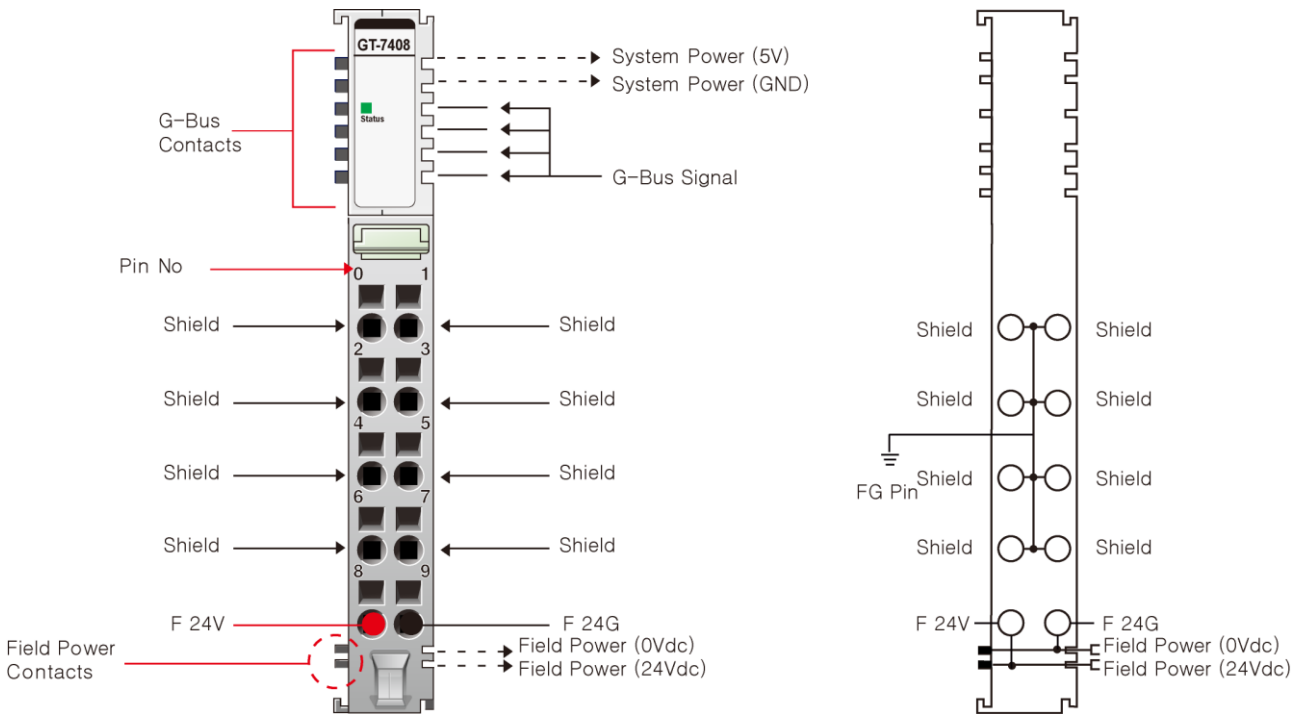

Pin No.	Signal Description	Signal Description	Pin No.
0	Shield	Shield	1
2	Shield	Shield	3
4	Shield	Shield	5
6	Shield	Shield	7
8	Field Power, 24V	Field Power, 24G	9



### 3.1.2. LED Indicator



LED No.	LED Function / Description	LED Color
Status	Internal Bus Status	Green

### 3.1.3. Status LED

Status	LED	To indicate
Normal signal.	Green	The unit is operating in normal condition. ( After normal initialization of G-Bus communication, this LED maintains ON status.)
Absence of network adapter	Off	Network adapter is not connected to this module.



### 3.1.4. Specification

Items	Specification
<b>Technical Data</b>	
UL Field Power	Supply voltage : 24Vdc nominal, Class 2
Field Power Voltage	24Vdc nominal
Field Power Contacts Current	Max. 10A Operating Temperature -40°C~50°C : Max. 10A 50°C~70°C : Max. 7A
Indicator	1 Green Internal Bus Status
<b>General Specification</b>	
System Power Dissipation	Max. 30mA @ 5Vdc
Wiring	I/O Cable Max. 2.0mm <sup>2</sup> (AWG 14)
Torque	0.8Nm(7 lb-in)
Weight	58g
Module Size	12mm x 99mm x 70mm
<b>Environment Condition</b>	<b>Refer to '4. Environment Specification'</b>

### 3.1.5. Example

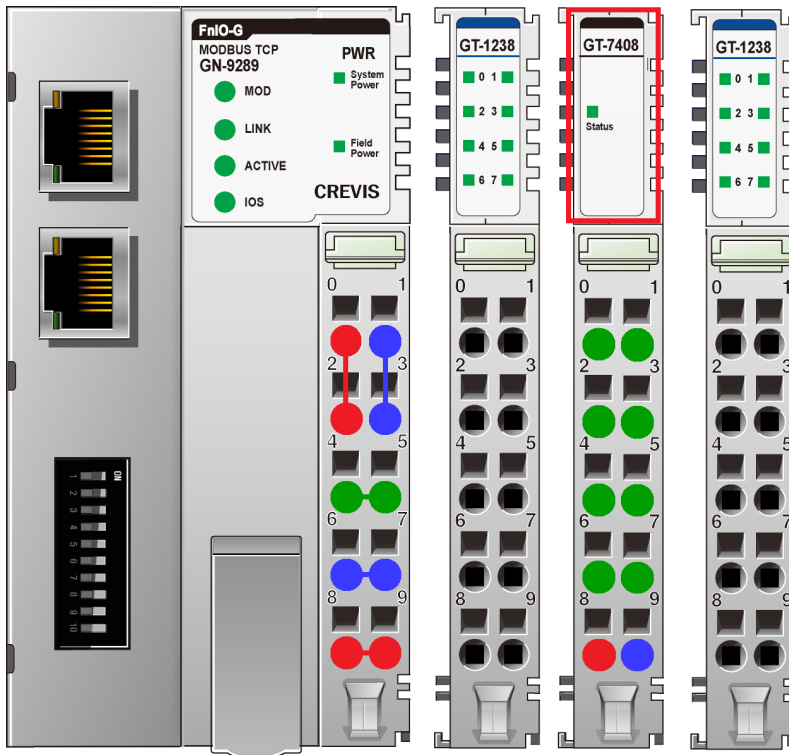
#### GT-7408 Shield



Color	System Power	Field Power
 Hole Number	0, 2	8, 9
 Hole Number	1, 3	6, 7
 Hole Number	4, 5 (F.G)	

### 3.2. GT-7508

#### 3.2.1. Wiring Diagram

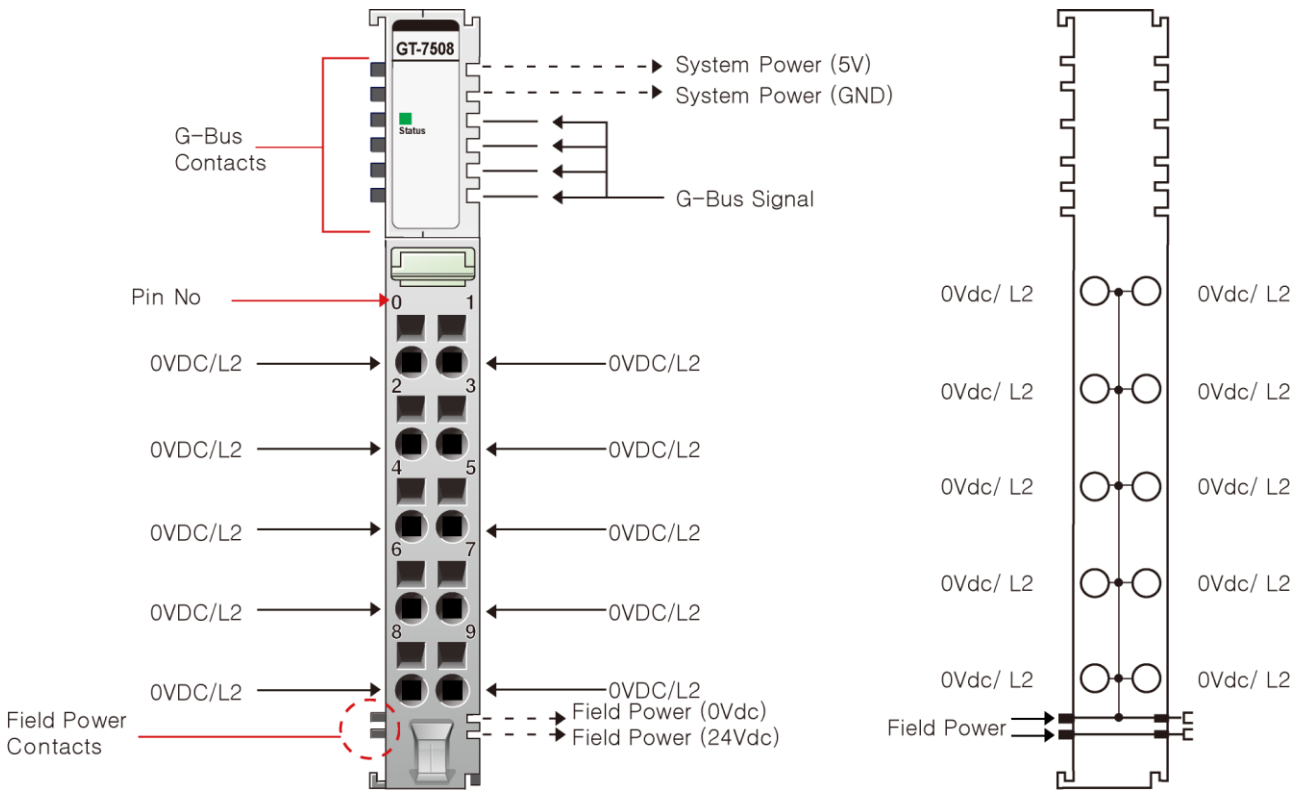

Pin No.	Signal Description	Signal Description	Pin No.
0	0VDC/L2	0VDC/L2	1
2	0VDC/L2	0VDC/L2	3
4	0VDC/L2	0VDC/L2	5
6	0VDC/L2	0VDC/L2	7
8	0VDC/L2	0VDC/L2	9

### 3.2.2. LED Indicator

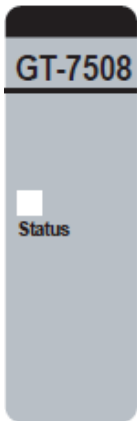

LED No.	LED Function / Description	LED Color
Status	Internal Bus Status	Green

### 3.2.3. Status LED

Status	LED	To indicate
Normal signal.	Green	The unit is operating in normal condition. ( After normal initialization of G-Bus communication, this LED maintains ON status.)
Absence of network adapter	Off	Network adapter is not connected to this module.

### 3.2.4. Specification

Items	Specification
<b>Technical Data</b>	
UL Field Power	Supply voltage : 24Vdc nominal, Class 2
Field Power Voltage	24Vdc nominal
Field Power Contacts Current	Max. 10A Operating Temperature -40°C~50°C : Max. 10A 50°C~70°C : Max. 7A
Indicator	1 Green Internal Bus Status
<b>General Specification</b>	
System Power Dissipation	Max. 30mA @ 5Vdc
Wiring	I/O Cable Max. 2.0mm <sup>2</sup> (AWG 14)
Torque	0.8Nm(7 lb-in)
Weight	70g Max.
Module Size	12mm x 99mm x 70mm
<b>Environment Condition</b>	<b>Refer to '4. Environment Specification'</b>

### 3.2.5. Example

#### GT-7508 Common 0Vdc

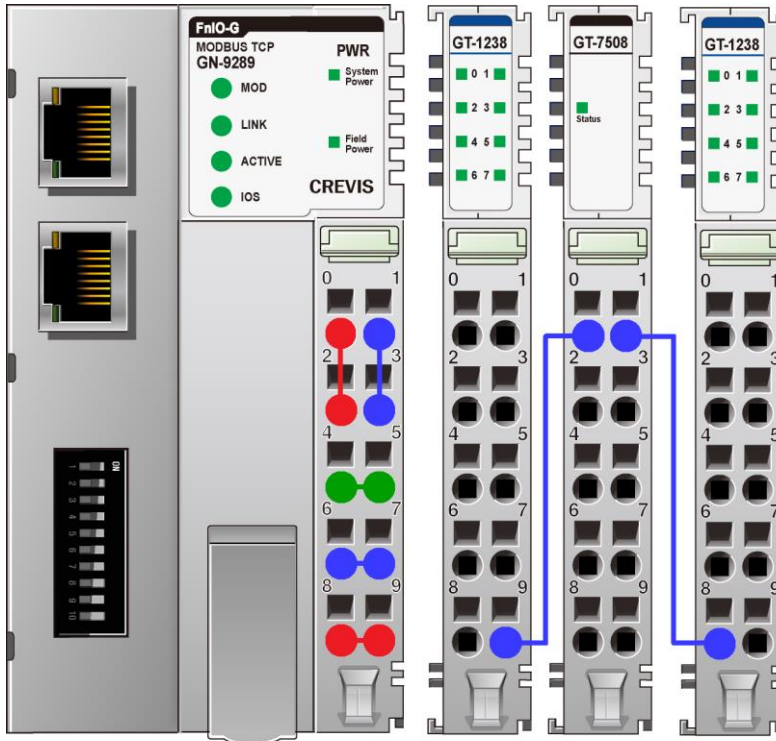

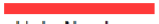
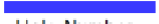
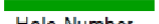
Color	System Power	Field Power
	0, 2	8, 9
	1, 3	6, 7
	4, 5 (F.G)	

### 3.3. GT-7511

#### 3.3.1. Wiring Diagram

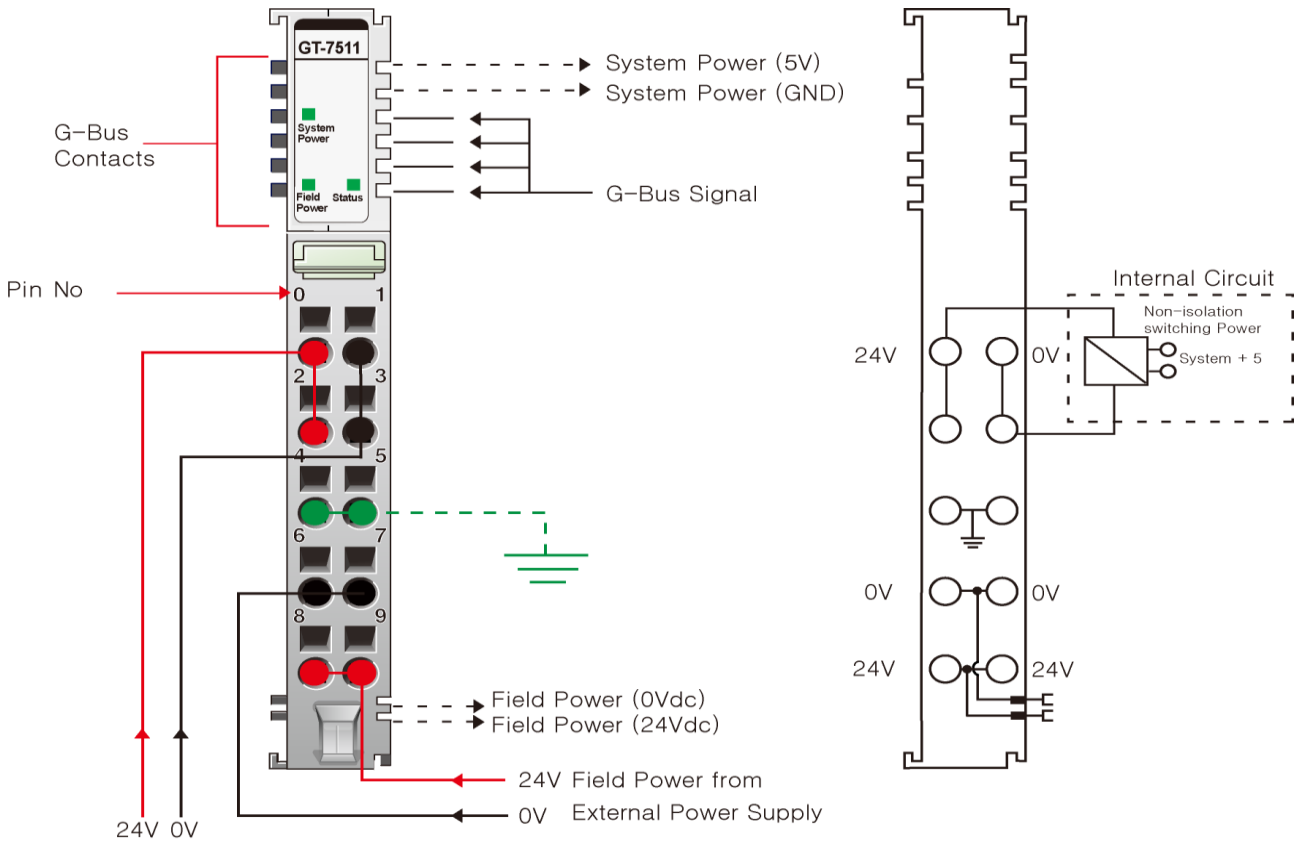

Pin No.	Signal Description	Signal Description	Pin No.
0	System Power, 24V	System Power, Ground	1
2	System Power, 24V	System Power, Ground	3
4	Frame Ground	Frame Ground	5
6	Field Power, Ground	Field Power, Ground	7
8	Field Power, 24V	Field Power, 24V	9

### 3.3.2. LED Indicator



LED No.	LED Function / Description	LED Color
System Power	System Power	Green
Field Power	Field Power	Green
Status	Internal Bus Status	Green

### 3.3.3. System/Field Power LED

Status	LED	To indicate
On Signal	Green	Normal Operation
Not Signal	Off	Not Supplied 24Vdc System / Field power

### 3.3.4. Status LED

Status	LED	To indicate
Normal signal.	Green	The unit is operating in normal condition. ( After normal initialization of G-Bus communication, this LED maintains ON status.)
Absence of data size.	Flashing green	Although this module is connected normally, there are not input/output data for communication.
Absence of Network adapter	Off	Network adapter is not connected to this module.

### 3.3.5. Specification

Items : GT-7511	
<b>Input Specification</b>	
System Input Voltage range	15Vdc to 30Vdc
System Power Input Voltage	24Vdc nominal
Indicators	1 Green System Power status , 1 Green Field Power status, 1 Green G-Bus status
UL Field Power	Supply voltage : 24Vdc nominal, Class 2
Field Power Input Voltage	24Vdc ( $\pm 20\%$ ) nominal
Field Power Contacts Current	Max. 10A Operating Temperature -40°C ~ 50°C : Max. 10A 50°C ~ 70°C : Max. 7A
G-Bus Output Voltage	Max. 5Vdc, 1A *
<b>General Specification</b>	
System Power Dissipation	Max. 20mA @ 24Vdc
Wring	I/O Cable Max. 2.0mm <sup>2</sup> (AWG 14)
Torque	0.8Nm(7 lb-in)
Weight	59g
Module size	12mm x 99mm x 70mm

\* Operating temperature

- 40 ~ 70°C temperature range specification can be guaranteed under the following conditions.

> Current for I/O modules : 0.4 A below.

> Otherwise, temperature specification can be guaranteed with -40 ~ 60°C.



### 3.3.6. Example

#### GT-7511 Provides the additional Power.

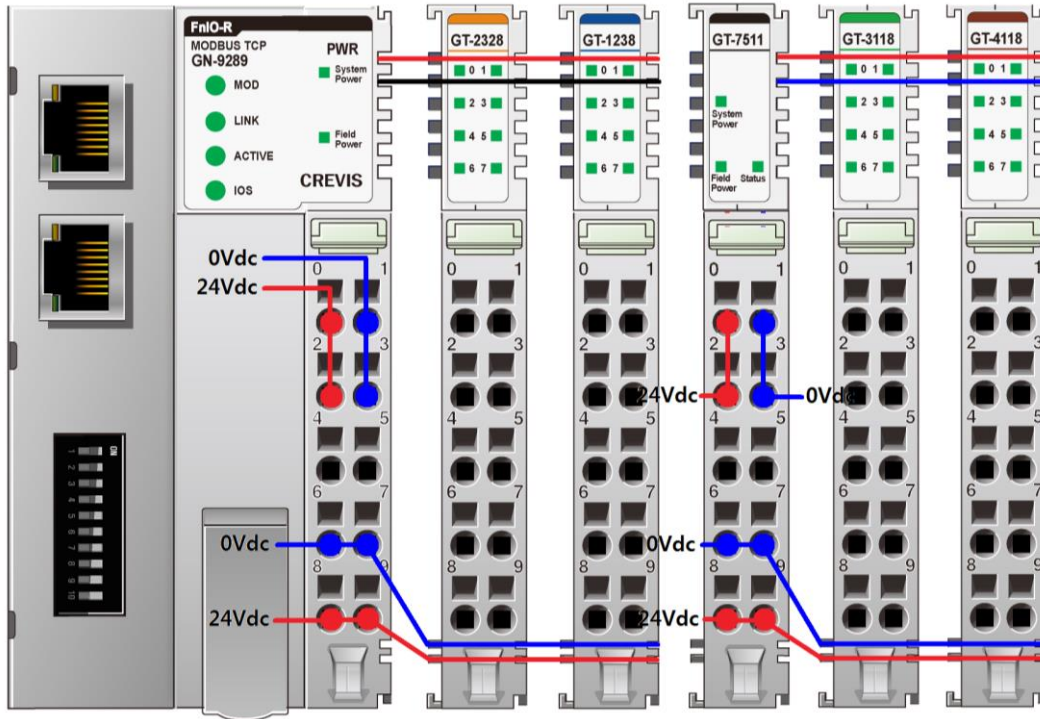

### 3.4. GT-7518

#### 3.4.1. Wiring Diagram

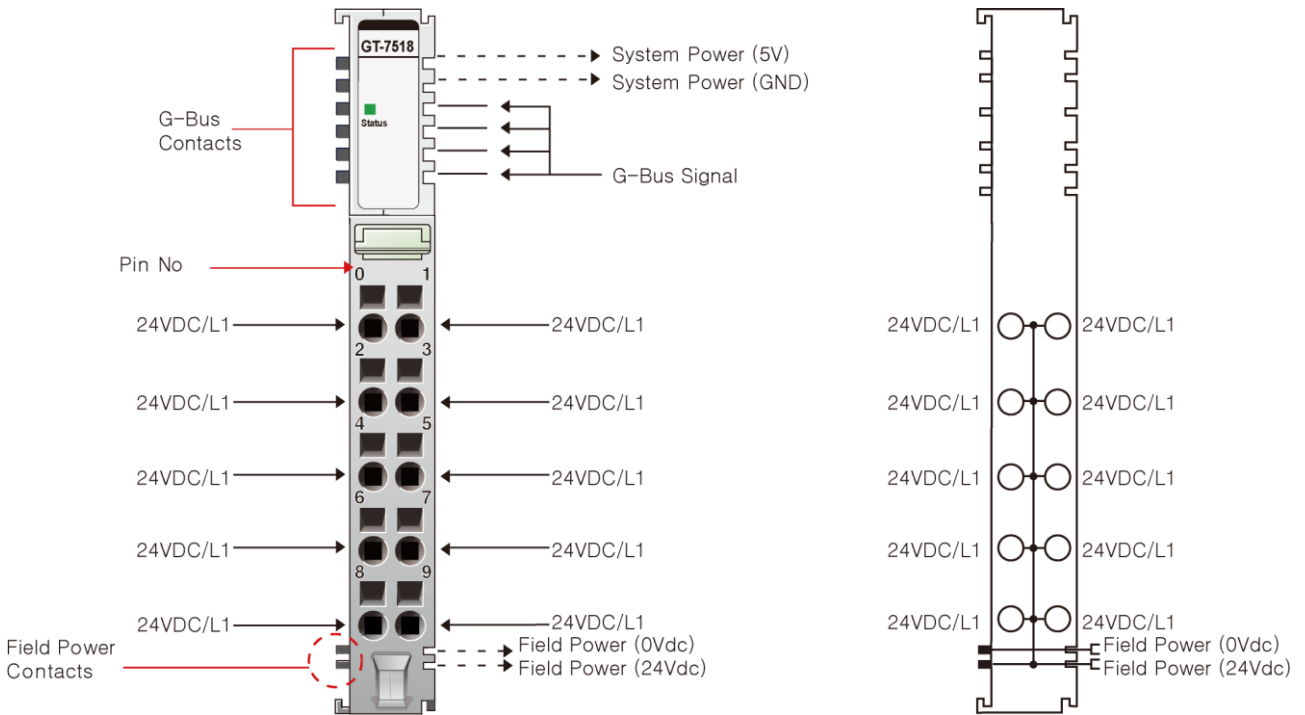

Pin No.	Signal Description	Signal Description	Pin No.
0	24VDC/L1	24VDC/L1	1
2	24VDC/L1	24VDC/L1	3
4	24VDC/L1	24VDC/L1	5
6	24VDC/L1	24VDC/L1	7
8	24VDC/L1	24VDC/L1	9

### 3.4.2. LED Indicator

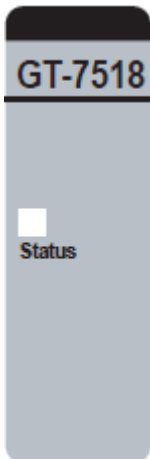

LED No.	LED Function / Description	LED Color
Status	Internal Bus Status	Green

### 3.4.3. Status LED

Status	LED	To indicate
Normal signal.	Green	The unit is operating in normal condition. ( After normal initialization of G-Bus communication, this LED maintains ON status.)
Absence of network adapter	Off	Network adapter is not connected to this module.



### 3.4.4. Specification

Items	Specification
<b>Technical Data</b>	
UL Field Power	Supply voltage : 24Vdc nominal, Class 2
Field Power Voltage	24Vdc nominal
Field Power Contacts Current	Max. 10A Operating Temperature -40°C~50°C : Max. 10A 50°C~70°C : Max. 7A
Indicator	1 Green Internal Bus Status
<b>General Specification</b>	
System Power Dissipation	Max. 30mA @ 5Vdc
Wiring	I/O Cable Max. 2.0mm <sup>2</sup> (AWG 14)
Torque	0.8Nm(7 lb-in)
Weight	58g
Module Size	12mm x 99mm x 70mm
<b>Environment Condition</b>	<b>Refer to '4. Environment Specification'</b>

### 3.4.5. Example

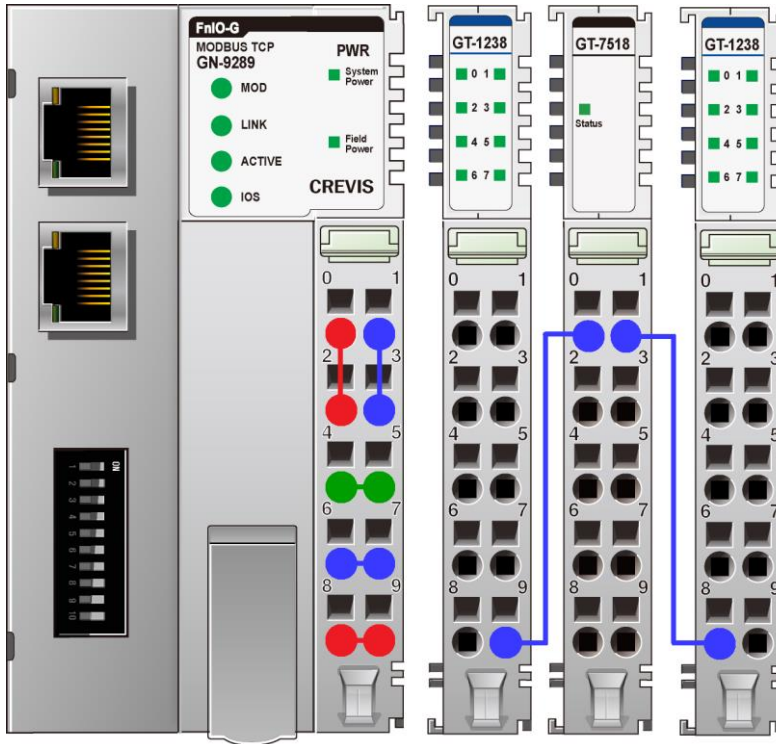
#### The GT-7518 Common 24Vdc



Color	System Power	Field Power
		
Hole Number	0, 2	8, 9
		
Hole Number	1, 3	6, 7
	4, 5 (F.G)	

### 3.5. GT-7588

#### 3.5.1. Wiring Diagram

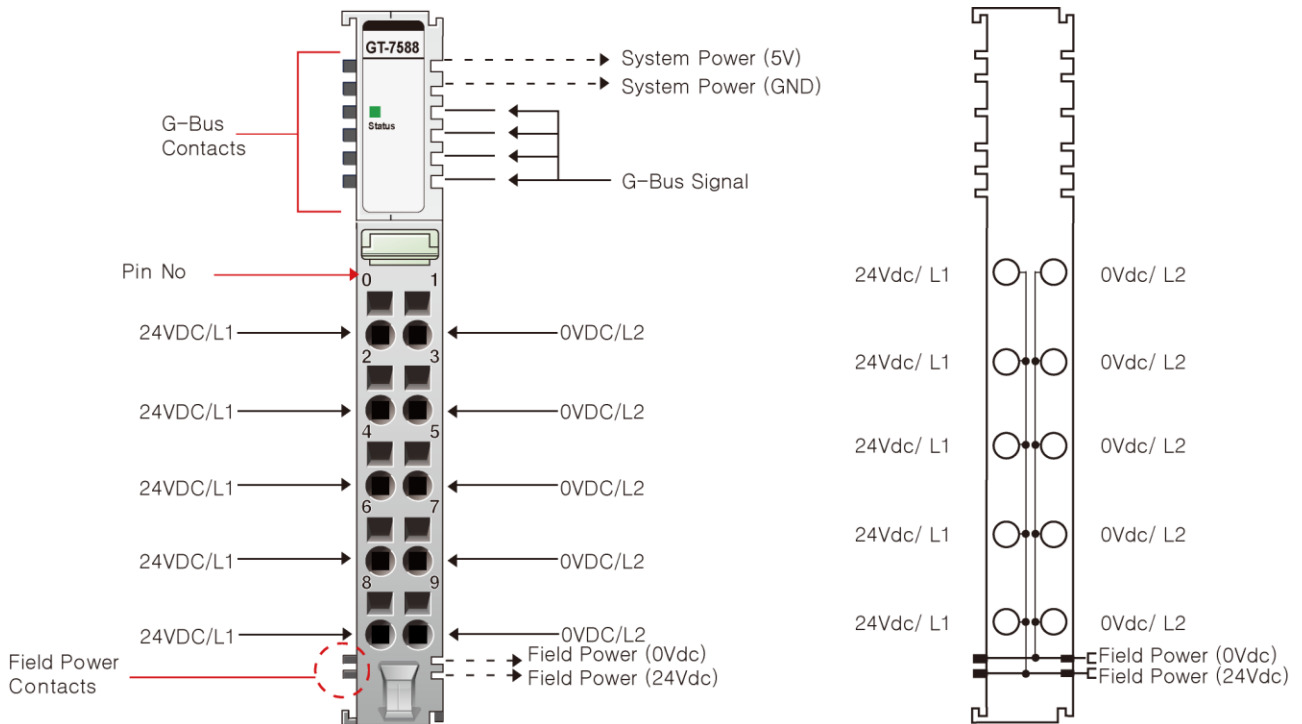

Pin No.	Signal Description	Signal Description	Pin No.
0	24VDC/L1	0VDC/L2	1
2	24VDC/L1	0VDC/L2	3
4	24VDC/L1	0VDC/L2	5
6	24VDC/L1	0VDC/L2	7
8	24VDC/L1	0VDC/L2	9

### 3.5.2. LED Indicator

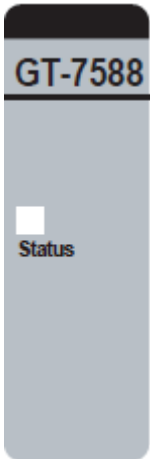

LED No.	LED Function / Description	LED Color
Status	Internal Bus Status	Green

### 3.5.3. Status LED

Status	LED	To indicate
Normal signal.	Green	The unit is operating in normal condition. ( After normal initialization of G-Bus communication, this LED maintains ON status.)
Absence of network adapter	Off	Network adapter is not connected to this module.

### 3.5.4. Specification

Items	Specification
<b>Technical Data</b>	
UL Field Power	Supply voltage : 24Vdc nominal, Class 2
Field Power Voltage	24Vdc nominal
Field Power Contacts Current	Max. 10A Operating Temperature -40℃~50℃ : Max. 10A 50℃~70℃ : Max. 7A
Indicator	1 Green Internal Bus Status
<b>General Specification</b>	
System Power Dissipation	Max. 30mA @ 5Vdc
Wiring	I/O Cable Max. 2.0mm <sup>2</sup> (AWG 14)
Torque	0.8Nm(7 lb-in)
Weight	58g
Module Size	12mm x 99mm x 70mm
<b>Environment Condition</b>	<b>Refer to '4. Environment Specification'</b>

### 3.5.5. Example

#### GT-7588 Common 24Vdc, 0Vdc

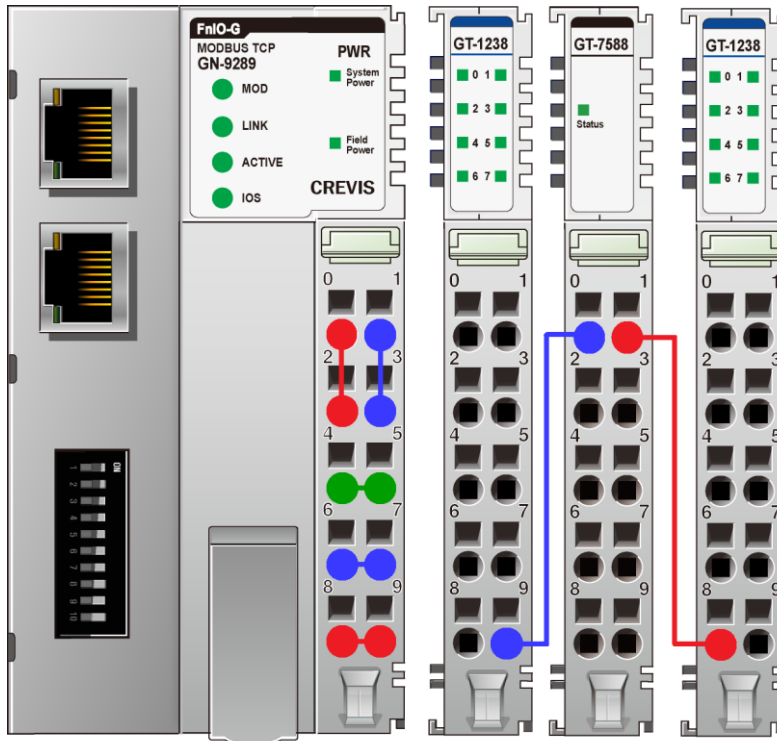

Color	System Power	Field Power
<span style="color: red;">█</span>	0, 2	8, 9
<span style="color: blue;">█</span>	1, 3	6, 7
<span style="color: green;">█</span>	4, 5 (F.G)	

### 3.6. GT-7641

#### 3.6.1. Wiring Diagram

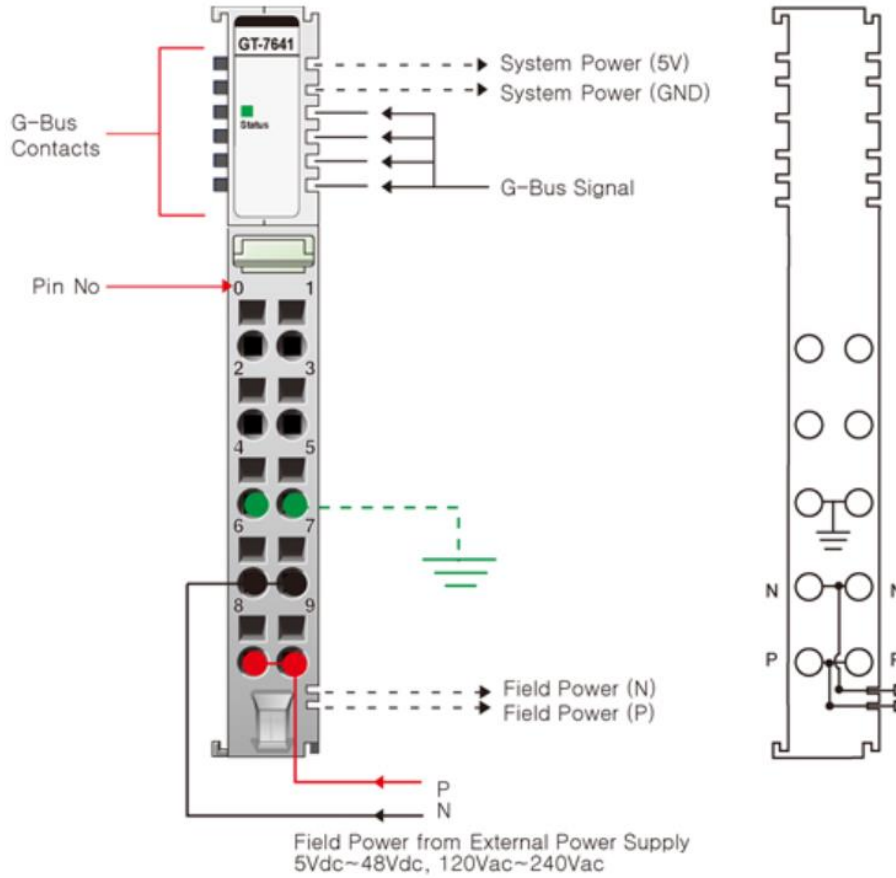

Pin No.	Signal Description	Signal Description	Pin No.
0	NC	NC	1
2	NC	NC	3
4	Frame Ground	Frame Ground	5
6	Field Power, Arbitrary (N)	Field Power, Arbitrary (N)	7
8	Field Power, Arbitrary (P)	Field Power, Arbitrary (P)	9



### 3.6.2. LED Indicator

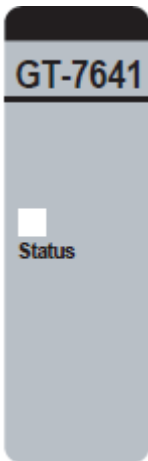

LED No.	LED Function / Description	LED Color
Status	Internal Bus Status	Green

### 3.5.3. Status LED

Status	LED	To indicate
Normal signal.	Green	The unit is operating in normal condition. ( After normal initialization of G-Bus communication, this LED maintains ON status.)
Absence of network adapter	Off	Network adapter is not connected to this module.

### 3.5.4. Specification

Items	Specification
<b>Technical Data</b>	
UL Field Power	Supply voltage : 24Vdc nominal, Class 2
Field Power Voltage	24Vdc nominal
Field Power Contacts Current	Max. 10A Operating Temperature -40°C~50°C : Max. 10A 50°C~70°C : Max. 7A
Indicator	1 Green Internal Bus Status
<b>General Specification</b>	
System Power Dissipation	Max. 30mA @ 5Vdc
Wiring	I/O Cable Max. 2.0mm <sup>2</sup> (AWG 14)
Torque	0.8Nm(7 lb-in)
Weight	58g
Module Size	12mm x 99mm x 70mm
<b>Environment Condition</b>	<b>Refer to '4. Environment Specification'</b>

### 3.5.5. Example

#### GT-7641 provides Field Power

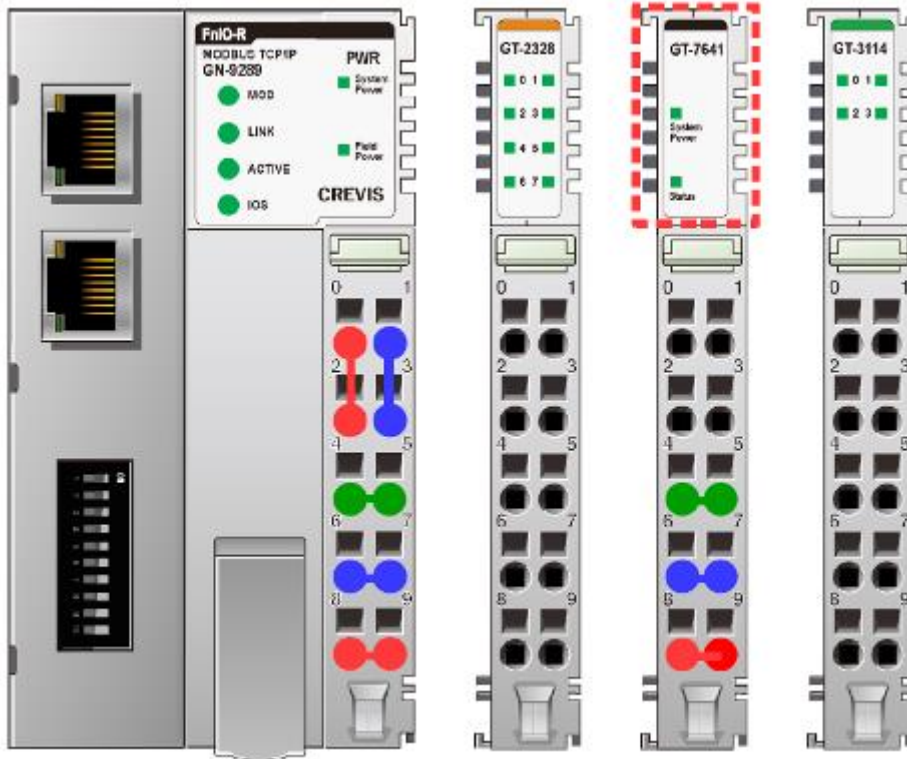

Color	System Power	Field Power
<span style="color: red;">█</span> Hole Number	0, 2	8, 9
<span style="color: blue;">█</span> Hole Number	1, 3	6, 7
<span style="color: green;">█</span> Hole Number	4, 5 (F.G)	

### 3.7. GT-7151

#### 3.7.1. Wiring Diagram

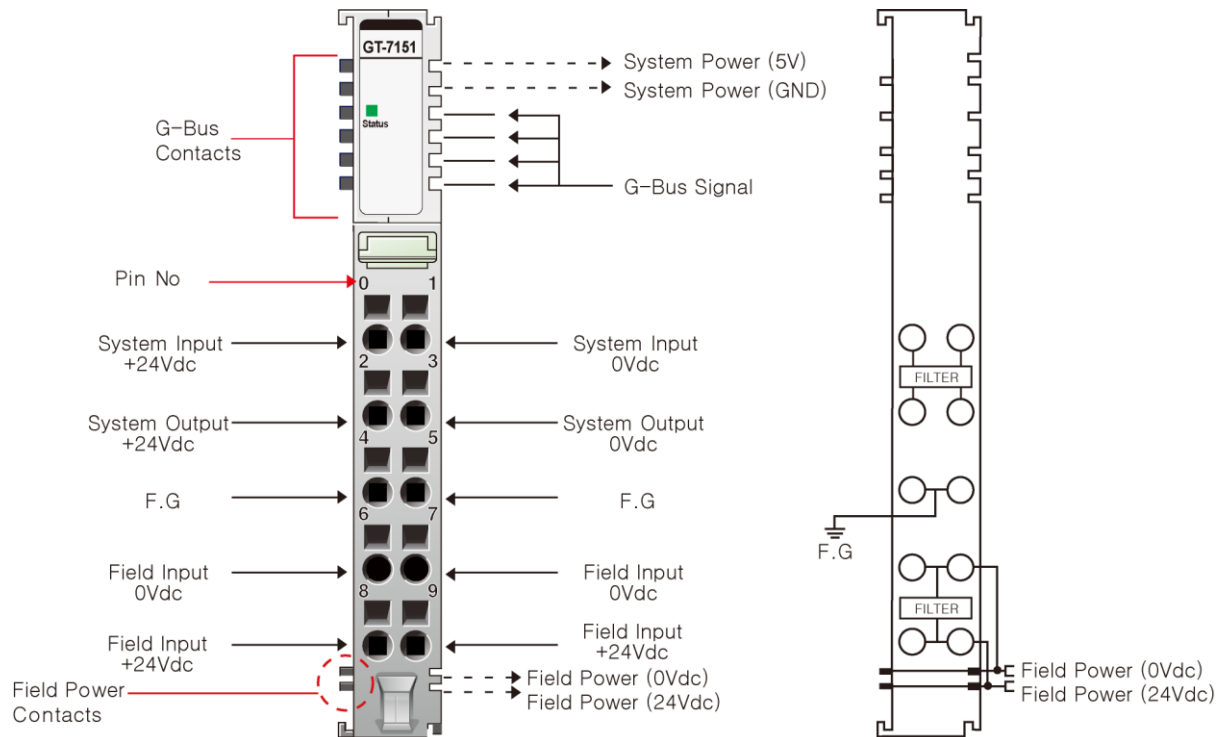

Pin No.	Signal Description	Signal Description	Pin No.
0	System Input +24Vdc	System Input 0Vdc	1
2	System Output +24Vdc	System Output 0Vdc	3
4	Frame Ground	Frame Ground	5
6	Field Input 0Vdc	Field Input 0Vdc	7
8	Field Input +24Vdc	Field Input +24Vdc	9

### 3.7.2. LED Indicator



LED No.	LED Function / Description	LED Color
Status	Internal Bus Status	Green

### 3.7.3. Status LED

Status	LED	To indicate
Normal signal.	Green	The unit is operating in normal condition. ( After normal initialization of G-Bus communication, this LED maintains ON status.)
Absence of network adapter	Off	Network adapter is not connected to this module.

### 3.7.4. Specification

Items	Specification
<b>Technical Data</b>	
Model description	Noise Filter Module, 18RTB, None ID Type
Input voltage	System / field 24Vdc(±20%)
Indicator	1 Green Internal Bus Status
System supply filter	Surge, EFT, Overcurrent protection
Field supply filter	Surge protection
Rated current system supply	< 1.5A @ 5V
Rated current field supply	< 10A
System output voltage	24Vdc(±20%)
<b>General Specification</b>	
System Power Dissipation	N/A (Not affecting your configuration)
Isolation	I/O to Logic : photocoupler isolation
UL Field Power	Supply voltage : 24Vdc nominal, Class 2
Field Power Voltage	24Vdc nominal
Wiring	I/O Cable Max. 2.0mm <sup>2</sup> (AWG 14)
Torque	0.8Nm(7 lb-in)
Weight	63g
Module Size	12mm x 99mm x 70mm
<b>Environment Condition</b>	<b>Refer to '4. Environment Specification'</b>

### 3.7.5. Example

#### Ex1) GT-7x51 wiring

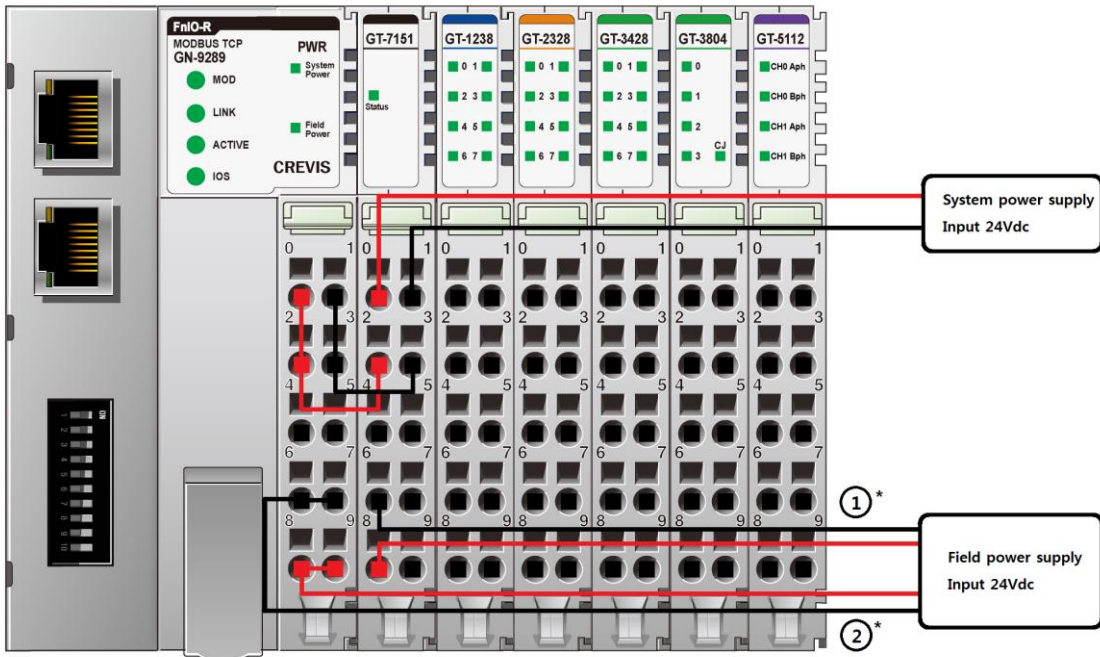

\* Use Only ① or ②

#### Ex2) GT-7x51 wiring

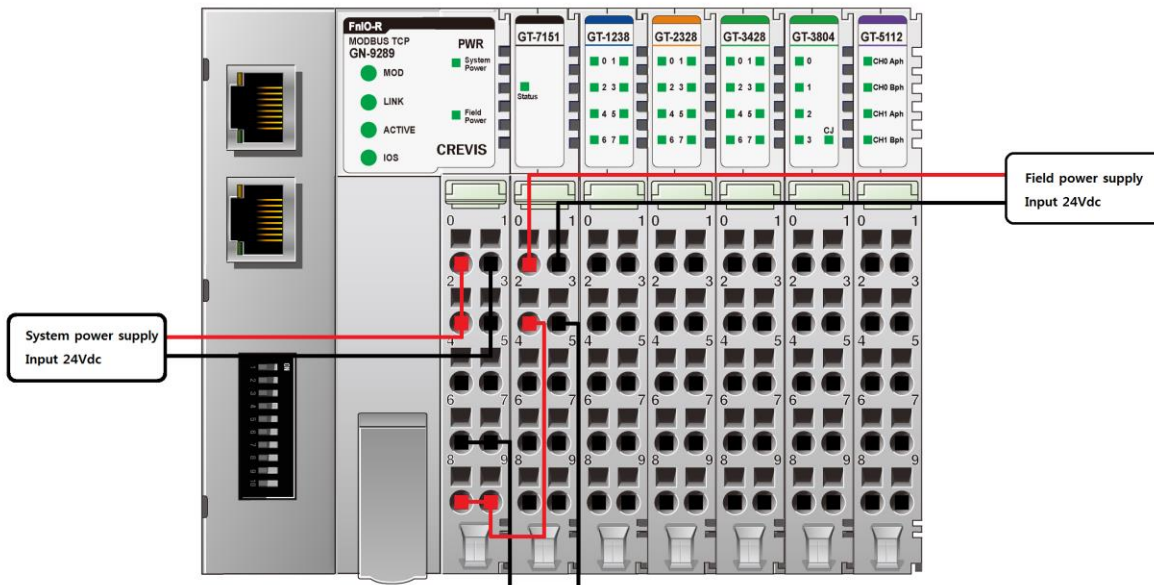

### 3.8. GT-7851

#### 3.8.1. Wiring Diagram

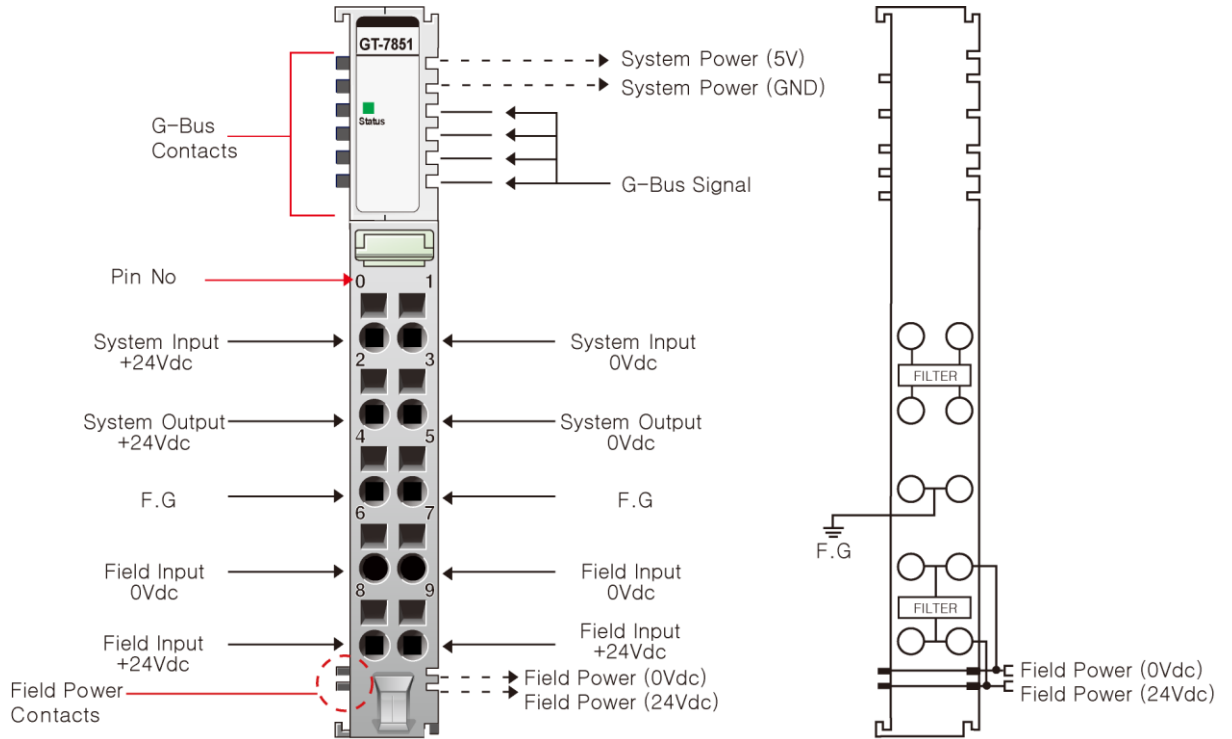

Pin No.	Signal Description	Signal Description	Pin No.
0	System Input +24Vdc	System Input 0Vdc	1
2	System Output +24Vdc	System Output 0Vdc	3
4	Frame Ground	Frame Ground	5
6	Field Input 0Vdc	Field Input 0Vdc	7
8	Field Input +24Vdc	Field Input +24Vdc	9

### 3.8.2. LED Indicator



LED No.	LED Function / Description	LED Color
Status	Internal Bus Status	Green

### 3.8.3. Status LED

Status	LED	To indicate
Normal signal.	Green	The unit is operating in normal condition. ( After normal initialization of G-Bus communication, this LED maintains ON status.)
Absence of network adapter	Off	Network adapter is not connected to this module.



### 3.8.4. Specification

Items	Specification
<b>Technical Data</b>	
Model description	Noise Filter Module, 18RTB, ID Type
Input voltage	System / field 24Vdc(±20%)
Indicator	1 Green Internal Bus Status
System supply filter	Surge, EFT, Overcurrent protection
Field supply filter	Surge protection
Rated current system supply	< 1.5A @ 5V
Rated current field supply	< 10A
System output voltage	24Vdc(±20%)
<b>General Specification</b>	
System Power Dissipation	Max. 30mA @ 5Vdc
Isolation	I/O to Logic : photocoupler isolation
UL Field Power	Supply voltage : 24Vdc nominal, Class 2
Field Power Voltage	24Vdc nominal
Wiring	I/O Cable Max. 2.0mm <sup>2</sup> (AWG 14)
Torque	0.8Nm(7 lb-in)
Weight	63g
Module Size	12mm x 99mm x 70mm
<b>Environment Condition</b>	<b>Refer to '4. Environment Specification'</b>

### 3.8.5. Example

#### Ex1) GT-7x51 wiring

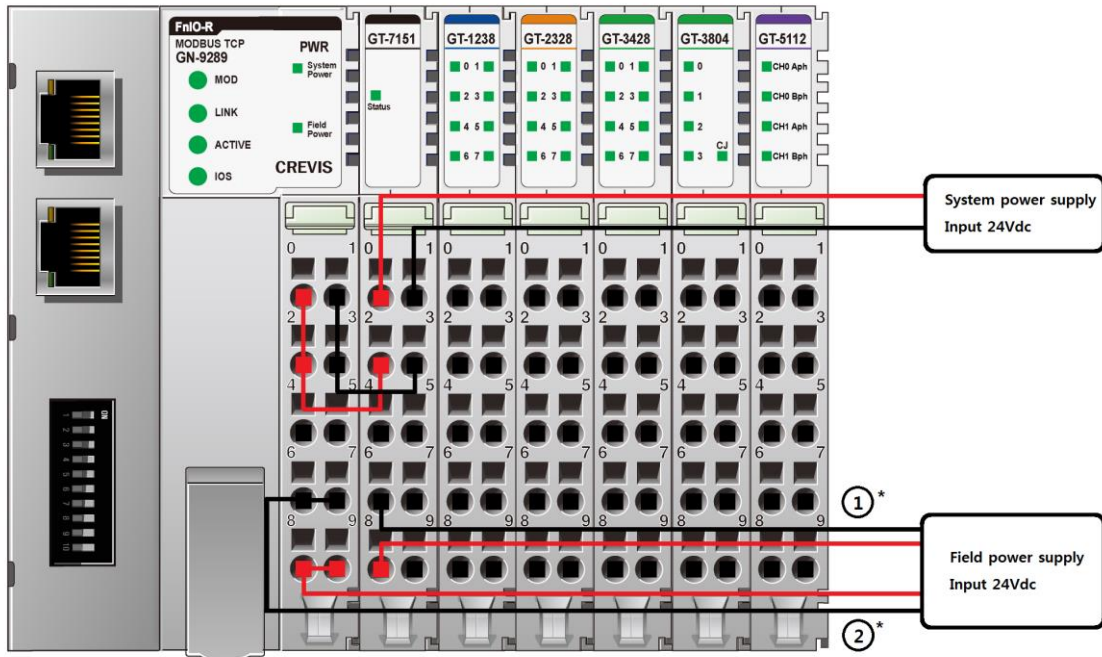

\* Use Only ① or ②

#### Ex2) GT-7x51 wiring

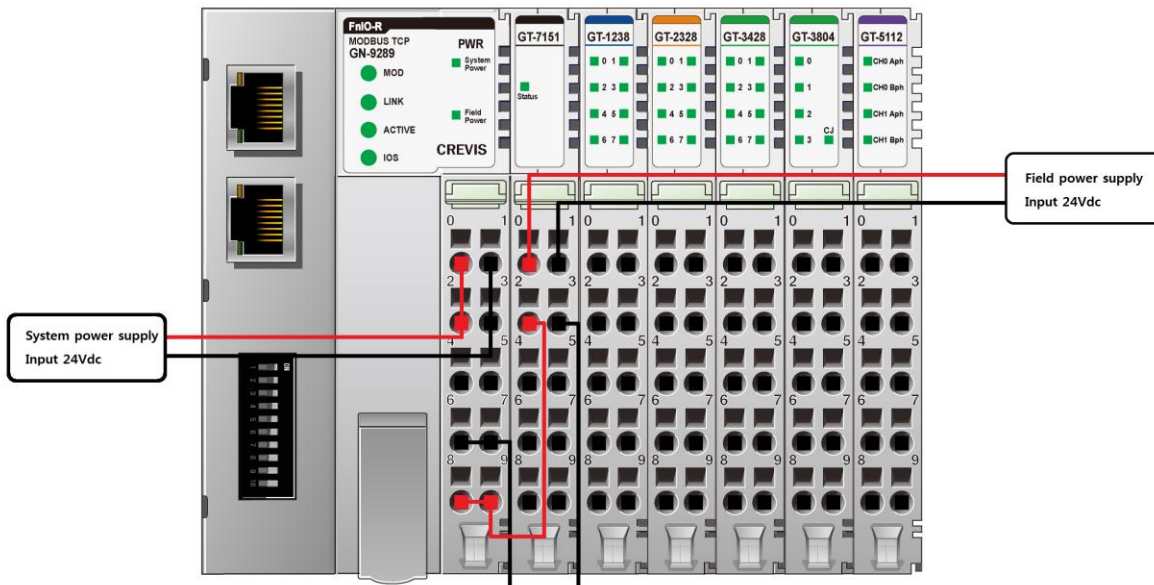

## 4. Environment Specification

<b>Environmental Specification</b>	
Operation Temperature	-40℃ ~ 70℃
UL Temperature	-20℃ ~ 60℃
Non-Operating Temperature	-40℃ ~ 85℃
Relative Humidity	5% ~ 90% Non-condensing
Mounting	DIN rail
<b>General Specification</b>	
Shock Operating	IEC 60068-2-27
Vibration Resistance	Based on IEC 60068-2-6 DNVGL-CG-0039 : Vibration Class B, 4g
Industrial Emissions	EN61000-6-4/All : 2011
Industrial Immunity	EN 61000-6-2 : 2005
Installation Position	Vertical and horizontal installation is available
Product Certifications	CE, UL, FCC

## 5. Dimension

### 5.1. GT-7XXX

(mm)

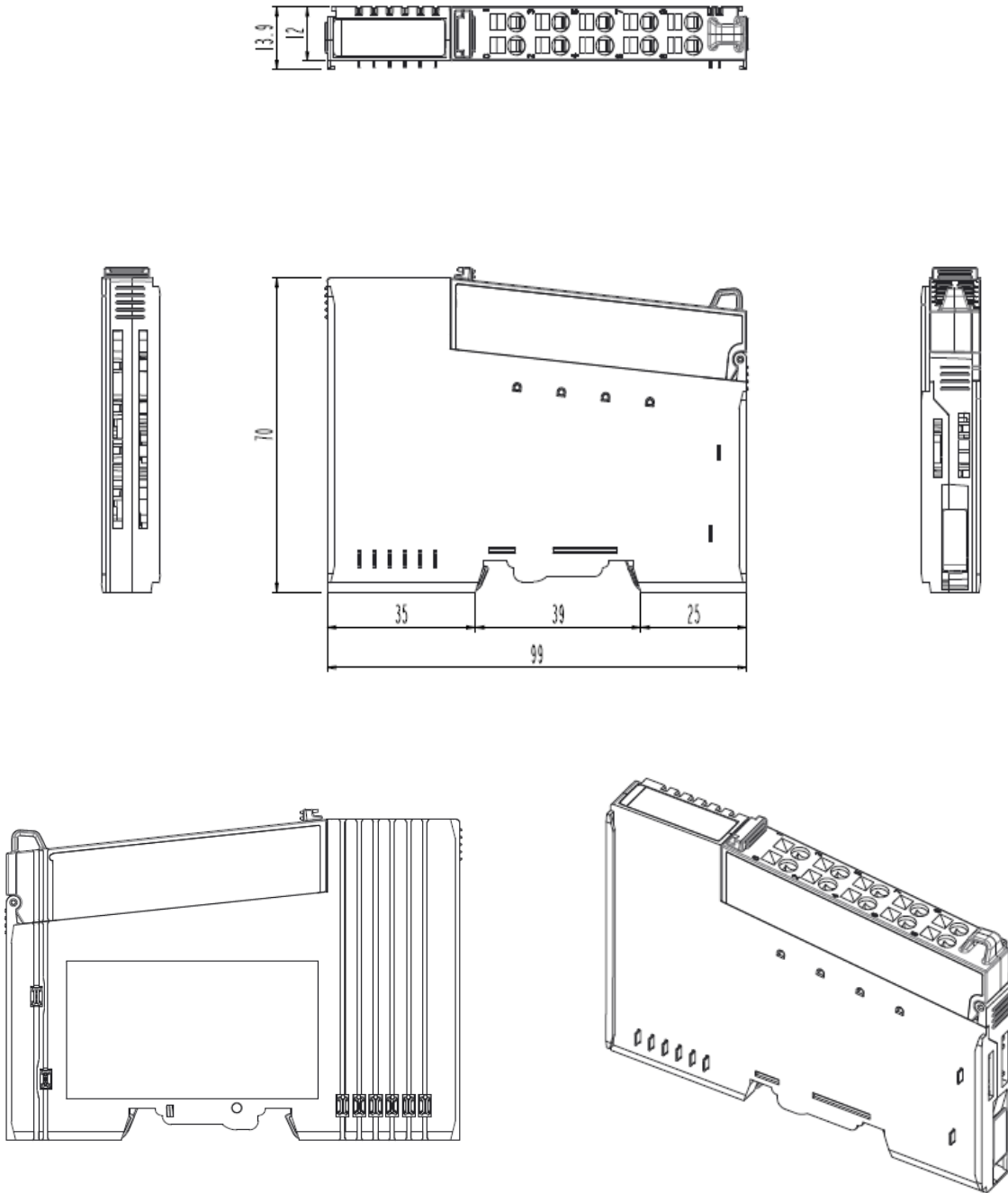

## 6. Mounting

### Caution!

- **Hot surface!**

The surface of the housing can become hot during operation. If the device was operated at high ambient temperatures, allow it to cool off before touching it.

### Notice!

- **Perform work on devices only if they are de-energized!**

Working on energized devices can damage them. Therefore, turn off the power supply before working on the devices.

### 6.1. I/O Inserting and Removing Devices

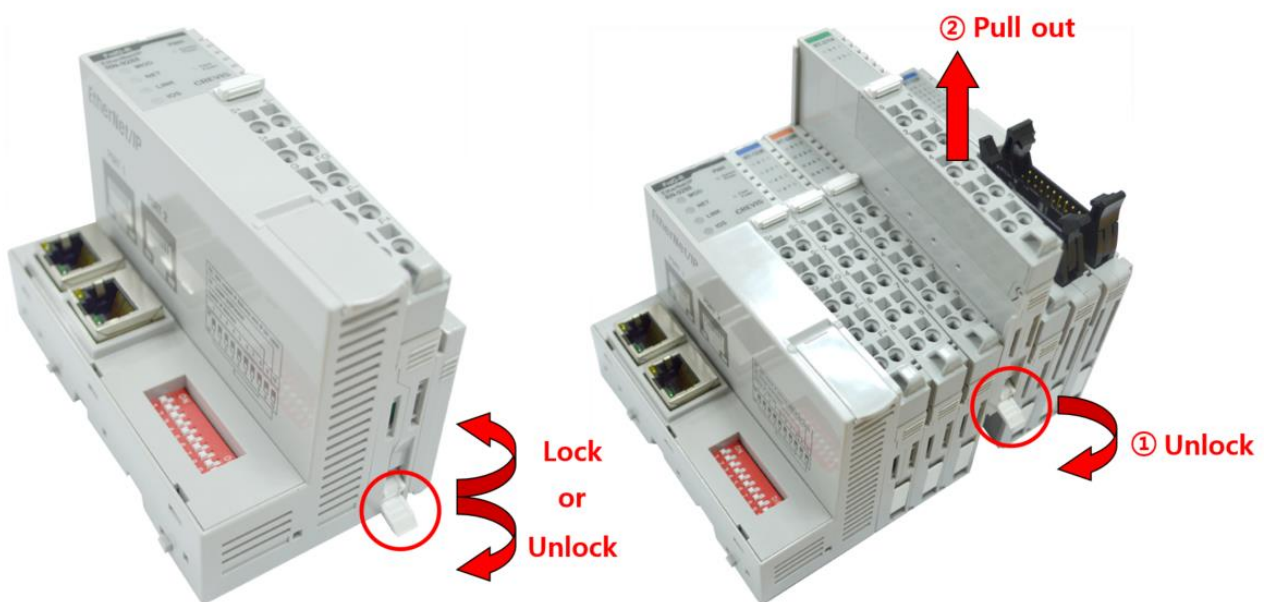

- As above figure in order to safeguard the FnIO module from jamming, it should be fixed onto the DIN rail with locking level. To do so, fold on the upper of the locking lever.  
To pull out the FnIO module, unfold the locking lever as below figure.

## 6.2. RTB (Removable Terminal Block)

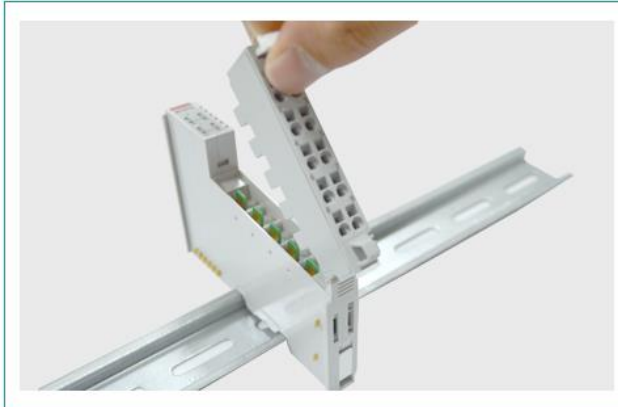
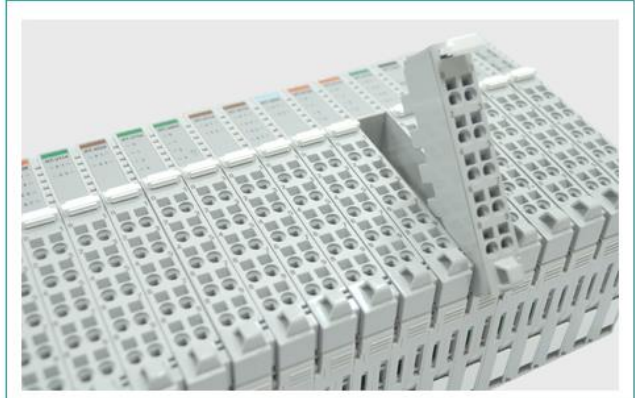

- Whole terminal block can be combined and removed for the convenience if its maintenance.
- There is a locking switch on the RTB for the easy combination and easy removal.
- Easy combination and easy removal for IO modules on the din rail through One Touch Locking Switch.

## 7. G-Bus Pin Description

Communication between the G-Series and the expansion module as well as system / field power supply of the bus modules is carried out via the internal bus. It is comprised of 6 data pin and 2 field power pin.

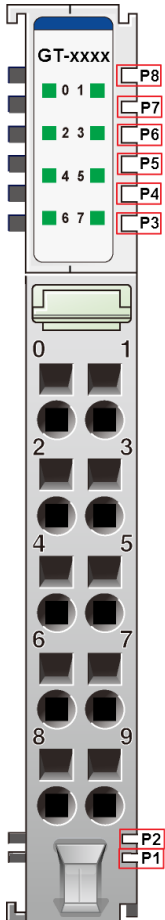

\*Please refer to the table below regarding the pin description from P1 to P8.

No.	Description
P1	Field Power (VCC)
P2	Field Power (GND)
P3	G-Bus CLK
P4	G-Bus MISO
P5	G-Bus MOSI
P6	G-Bus Token
P7	System Power (GND)
P8	System Power (VCC)

**DANGER**



Do not touch data and field power pins in order to avoid soiling and damage by ESD noise.

## 8. Trouble Shooting

### DANGER



In this manual, all variety cases can't be described.

If you can't find any fault after investigating all below cases, please refer to user manuals of G-Series Network adapters.

LED Status	Cause	Action
EXPANSION MODULE	Not Power	Device has no expansion Module or may not be powered.
<b><u>STATUS LED</u></b>		
Off	No Initialized	The Parameter is not initialized yet
Green	G-Bus Connection	G-Bus normal Operation
Flashing Green	G-Bus Ready	G-Bus ready
Flashing Red	G-Bus Fault	G-Bus Time Out, G-Bus Failed Communication
Red	Device Fault	Device fault
<b><u>CHANNEL STATUS LED</u></b>		
Off	Not Signal	Normal Operation
Green	On Signal	Normal Operation