



Main Features

- ◆ Compact and fanless design
- ◆ Built-in GPS receiver with optional dead reckoning function
- ◆ Variety of wireless communication options
- ◆ Smart power management with Ignition on/off delay via software control and low voltage protection
- ◆ Wide range DC input from 9~36V
- ◆ EN50155 Class OT4 conformity
- ◆ Compliance to EN45545-2
- ◆ 5 x RS232 and 2 x RS485

Product Overview

nROK 1020, a compact, rugged and entry-level railway computer with Intel Atom® x5-E3930 processor dual core 1.8GHz, is designed for the harsh railway related applications. Because of the compact design, it is easy to be located without compromising its features.

Adopting lock concept, LAN, Power-in and Audio, are all designed against vibration and shock impact. An advanced GPS receiver supports GPS/Gloness/QZSS/Galileo/Beidou and optional dead reckoning module is also available. Thanks to 2 mini-PCIe socket, nROK 1020 is perfectly suited for wireless applications, such as WLAN and WWAN data and voice transmission. With external SIM socket, it allows users to access SIM card conveniently. 12VDC output can be provided for external display with easy power wire arrangement. nROK 1020 is very suitable for Passenger Information System, Automatic Fare Collections and digital radio data/voice transmission applications.

Specifications

CPU

- ◆ Intel Atom® x5-E3930 processor dual core 1.8GHz

Memory

- ◆ 1 x 204-pin DDR3L SO-DIMM socket support 1867MHz up to 8GB. Default 4GB

Expansion

- ◆ 1 x Full size mini-PCIe socket (USB 2.0) for LTE module with 1 x external SIM
- ◆ 1 x Full size mini-PCIe socket (PCIe 2.0, USB 2.0, mSATA)

Function

- ◆ 1 x u-blox NEO-M8N module (support GPS/Gloness/QZSS/Galileo/Beidou) or optional module with Dead Reckoning
- ◆ Built-in G-sensor
- ◆ Built-in TPM

I/O Interface-Front

- ◆ 1 x power button
- ◆ 4 x LED indicators for Status (programmable), Storage, WLAN and WWAN
- ◆ 1 x system reset button
- ◆ 2 x type A USB 3.0 compliant host, supporting system boot up
- ◆ 1 x DB-15 VGA
- ◆ 1 x HDMI

- ◆ 1 x external SIM card socket
- ◆ 1 x circular connector for 9~36VDC input with ignition and 20W typical power consumption
- ◆ 1 x circular connector for Audio-In and Audio-Out
- ◆ 1 x M12 connector for 10/100/1000Mbps Ethernet

I/O Interface-Rear

- ◆ 1 x 12V/2A DC output, SMBus, power button
- ◆ 1 x DB15 COM port for 4 x RS232 Tx/Rx and 2 x RS485
- ◆ 1 x DB15 for multi port
 - 1 x CAN2.0
 - 1 x RS232 Tx/Rx
 - 1 x odometer and direction for optional DR
 - 5 x programmable DIO
- ◆ Input voltage (internal type): 5VDC TTL (default)
- ◆ Input voltage (source type): 3~24VDC
- ◆ Digital output (sink type): 5VDC TTL (default), max current: 20mA
- ◆ Digital output (source type): 3~24VDC
- ◆ 3 x Antenna hole for SMA-type antenna (WWAN/WLAN/GPS)

Expandable Storage

- ◆ 1 x 2.5" SSD SATA 3.0
- ◆ 1 x mSATA

Dimension Drawing

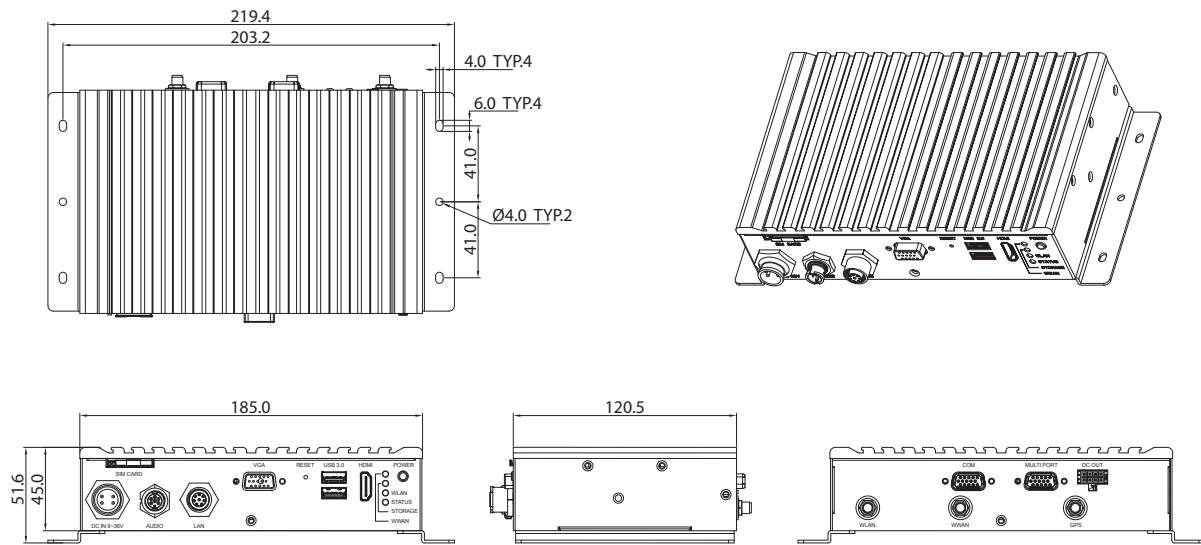

Operating System

- Windows 10
- Linux

Power Management

- Power input 9~36VDC w/o isolation
- Selectable boot - up & shut - down voltage for low power protection
- HW design ready for 8-level delay time on/off at user's self configuration
- Power on/off ignition, software detectable
- Support S3, S4 suspend mode

Dimensions & Weight

- 185mm (W) x 120mm (D) x 45mm (H) (7.3" x 4.7" x 1.8")
- 1 kg (2.20 lbs)

Construction

- Aluminum top case with sheet metal

Environment

- Operating temperatures:
 - EN 50155 class OT4 -40~70°C, 85°C for 10 minutes (w/ industrial SSD) with air flow
- Storage temperatures: -40°C to 85°C
- Relative humidity: 10% to 90% (non-condensing)
- Vibration:
 - Vibration (random): 2g @5~500 Hz
 - Operating: MIL-STD-810F, Method 514.5, Category 20, Ground Vehicle – Highway Truck

Storage: MIL-STD-810F, Method 514.5, Category 24, Integrity Test

- Shock:
 - Operating: MIL-STD-810F, Method 516.5, Procedure I, Trucks and semi-trailers=20g
 - Crash hazard: MIL-STD-810F, Method 516.5, Procedure V, Ground equipment=75g

Standards/Certifications

- CE
- FCC Class A
- EN 50155: 2017
 - Ambient temperature EN 50155 Class OT4 (-40~70°C), 85°C for 10 minutes
 - Interruptions of voltage supply class S1
 - Supply change over class C1, C2
- EMC EN 50121-3-2: 2016
- Environment EN 60068-2-1, EN 60068-2-2
- Shock and vibration IEC 61373 Class B
- Protective coating class PC1 (PC2, by request)
- EN 45545-2: 2013+A1:2015

Ordering Information

- **nROK 1020-A (P/N: 10V00102002X0)**
 Intel Atom® x5-E3930 processor 1.8GHz with 4GB DDR3L, U-blox GPS module, GPS antenna, EN50155 Class OT4(24VDC w/o isolation)