



FEATURES

- 17" TFT LED with Resistive Touch
- Intel 6th Gen Core i3-6100U / i5-6200U
- 1x DDR4L 2133MHz 4GB, Up to 16GB
- Multi ports for option: VGA/HDMI/LAN/USB/COM
- DC 12V-24V Input, (+9V~36V) wide voltage input optional
- IP65 Compliant Front Panel

SPECIFICATIONS

System		Touch screen	
CPU	Intel Core i3-6100U / i5-6200U / Celeron 3855U	Touch Screen Type	5 wire resistive touch
L2 Cache	2MB / 3MB	Transmittance	>85%
Chipsets	Intel 6th Skylake-U SOC	Response Time	<5ms
Memory	DDR4L 2133MHz 4GB, Up to 16GB	Surface Hardness	≥3H
Harddisk	1 x mSATA 32G SSD / (64G / 128G / 250G / 500G SSD) Optional	Supply Voltage	5.0V DC
Graphics	Intel HD Graphics 520	Touch Life	≥ 1000W
Network	Intel® i211 1000 Mbps port	Instituional	
Audio	Realtek ACL662 Audio controller	Material	Aluminum Alloy Shell
Operation System	Windows7 / 8 / 10, Linux, Unix, QNX	Color	Silver / Black (optional)
I / O		VESA Mounting	Cantilever bracket
VGA	1 x VGA / 1 x HD-MI	Waterproof Rate	IP65
LAN	1 x LAN	Product Dimension	400 x 390 x 155 mm
USB	2 x USB2.0 / 2 x USB3.0	Cut-out Size	/
IDEC Switch	Start / Select / Reset / Key/ Stop switch (Optional)	Packing Size	500 x 340 x 450 mm
Wireless Network	WiFi + Bluetooth (Optional)	Gross Weight	16.0 KG
Other I/O Interface	1 x Power Switch	Power and Environment	
LCD Panel		Operating Temperature	-10~60°C
Panel Size	17" Led	Storage Temperature	-20~80°C(-22~176°F)
Resolution	1280 x 1024	Relative Humidity	5%~95%@40°C, non-condensing
Aspect Ratio	5:4	Vibration Range	5-500 Hz, 0.026 G2/Hz, 2.16 Grms, X, Y, Z, 1 hour per axis
Display Brightness	400 cd/m2		
Contrast Ratio	1000:1	External Power Supply	AC 100 - 240V~50/60Hz,1.5A
Backlight Lifetime	50000 Hr (min.)	Working Voltage	DC 12V~24V / optional(+9V~36V)
Viewing Angle	88 / 88 / 88 / 88 (CR≥10) (L / R / U / D)	Power Consumption	≤30W



Dimension & I/O

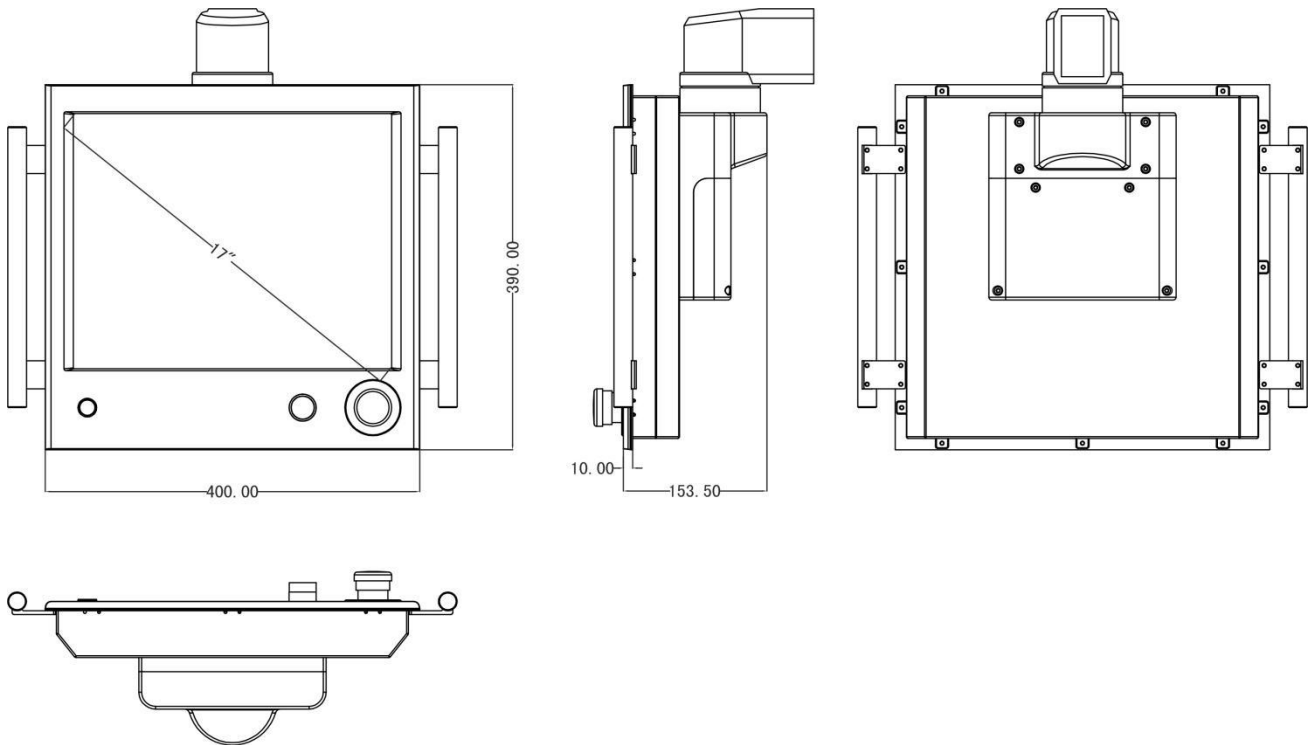

ORDERING INFORMATION

PACKING LIST

- 1x DCP-0017SBR Series Device Control Panel
- 1x Utility DVD Driver
- 1x Power Adaptor

AVAILABLE MODELS

Display Size	Resolution	Format	Brightness(cd/m ²)	Viewing Angle	LCD Color	Backlight MTBF
15.6"	1920x1080	16:9	600cd/m ²	80/80/80/65	262K/16.2M	50000 Hr (min.)
17"	1280x1024	5:4	400cd/m ²	88/88/88/88	262K/16.7M	50000 Hr (min.)
19"	1280x1024	5:4	450cd/m ²	85/85/80/80	262K/16.7M	50000 Hr (min.)
21.5"	1920x1080	16:9	250cd/m ²	89/89/89/89	262K/16.7M	50000 Hr (min.)



IP SYSTEMES
 8 rue du Colonel Chambonnet – BP67
 69672 BRON Cedex
 Tel. : 04 72 14 18 00
 Fax : 04 72 14 18 01
www.ip-systemes.com – info@ip-systemes.fr

