

Analog Output Module

GT-4xxx User Manual



DOCUMENT CHANGE SUMMARY				
REV	PAGE	REMARKS	DATE	EDITOR
1.00	New Document		18/07/30	JY,Hyun
1.01		Add Product GT-4154, GT-4158,	19/01/16	JY,Hyun
1.02		Add Product GT-4214, GT-4254, GT-4218, GT-4258	20/08/19	JY,Hyun

 Table of Contents

1. Important Notes	6
1.1. Safety Instruction	7
1.1.1. Symbols	7
1.1.2. Safety Notes	7
1.1.3. Certification	7
2. Analog Output Module List	8
3. Specification	9
3.1. GT-4114	9
3.1.1. Wiring Diagram	9
3.1.2. LED Indicator	10
3.1.3. Channel Status LED	10
3.1.4. Environment Specification	11
3.1.5. Specification	12
3.1.6. Data Value / Current	13
3.1.7. Mapping Data into the Image Table.	14
3.1.8. Parameter Data	14
3.2. GT-4154	15
3.2.1. Wiring Diagram	15
3.2.2. LED Indicator	16
3.2.3. Channel Status LED	16
3.2.4. Environment Specification	17
3.2.5. Specification	18
3.2.6. Data Value / Current	19
3.2.7. Mapping Data into the Image Table.	20
3.2.8. Parameter Data	20
3.3. GT-4118	21
3.3.1. Wiring Diagram	21
3.3.2. LED Indicator	22
3.3.3. Channel Status LED	22
3.3.4. Environment Specification	23
3.3.5. Specification	24

3.3.6. Data Value / Current.....	25
3.3.7. Mapping Data into the Image Table.	26
3.3.8. Parameter Data.....	27
3.4. GT-4158	28
3.4.1. Wiring Diagram	28
3.4.2. LED Indicator.....	29
3.4.3. Channel Status LED.....	29
3.4.4. Environment Specification	30
3.4.5. Specification.....	31
3.4.6. Data Value / Current.....	32
3.4.7. Mapping Data into the Image Table.	33
3.4.8. Parameter Data.....	34
3.5. GT-4214	35
3.5.1. Wiring Diagram	35
3.5.2. LED Indicator.....	36
3.5.3. Channel Status LED.....	36
3.5.4. Environment Specification	37
3.5.5. Specification.....	38
3.5.6. Data Value / Current.....	39
3.5.7. Mapping Data into the Image Table.	40
3.5.8. Parameter Data.....	40
3.6. GT-4254	41
3.6.1. Wiring Diagram	41
3.6.2. LED Indicator.....	42
3.6.3. Channel Status LED.....	42
3.6.4. Environment Specification	43
3.6.5. Specification.....	44
3.6.6. Data Value / Current.....	45
3.6.7. Mapping Data into the Image Table.	46
3.6.8. Parameter Data.....	46
3.7. GT-4218	47
3.7.1. Wiring Diagram	47

3.7.2. LED Indicator.....	48
3.7.3. Channel Status LED.....	48
3.7.4. Environment Specification.....	49
3.7.5. Specification.....	50
3.7.6. Data Value / Current.....	51
3.7.7. Mapping Data into the Image Table.	52
3.7.8. Parameter Data.....	53
3.8. GT-4258	54
3.8.1. Wiring Diagram	54
3.8.2. LED Indicator.....	55
3.8.3. Channel Status LED.....	55
3.8.4. Environment Specification.....	56
3.8.5. Specification.....	57
3.8.6. Data Value / Current.....	58
3.8.7. Mapping Data into the Image Table.	59
3.8.8. Parameter Data.....	60
4. Dimension	61
4.1. GT-4xx4(RTB)	61
5. Mounting.....	62
5.1. I/O Inserting and Removing Devices.....	62
5.2. RTB (Removable Terminal Block)	63
6. G-Bus Pin Description	64

1. Important Notes

Solid state equipment has operational characteristics differing from those of electromechanical equipment.

Safety Guidelines for the Application, Installation and Maintenance of Solid State Controls describes some important differences between solid state equipment and hard-wired electromechanical devices.

Because of this difference, and also because of the wide variety of uses for solid state equipment, all persons responsible for applying this equipment must satisfy themselves that each intended application of this equipment is acceptable.

In no event will CREVIS be responsible or liable for indirect or consequential damages resulting from the use or application of this equipment.

The examples and diagrams in this manual are included solely for illustrative purposes. Because of the many variables and requirements associated with any particular installation, CREVIS cannot assume responsibility or liability for actual use based on the examples and diagrams.

Warning!



- ✓ **If you don't follow the directions, it could cause a personal injury, damage to the equipment or explosion**
- Do not assemble the products and wire with power applied to the system. Else it may cause an electric arc, which can result into unexpected and potentially dangerous action by field devices. Arching is explosion risk in hazardous locations. Be sure that the area is non-hazardous or remove system power appropriately before assembling or wiring the modules.
- Do not touch any terminal blocks or IO modules when system is running. Else it may cause the unit to an electric shock or malfunction.
- Keep away from the strange metallic materials not related to the unit and wiring works should be controlled by the electric expert engineer. Else it may cause the unit to a fire, electric shock or malfunction

Caution!

- ✓ **If you disobey the instructions, there may be possibility of personal injury, damage to equipment or explosion. Please follow below Instructions.**
- " Check the rated voltage and terminal array before wiring. Avoid the circumstances over 50°C of temperature. Avoid placing it directly in the sunlight.
- " Avoid the place under circumstances over 85% of humidity.
- " Do not place Modules near by the inflammable material. Else it may cause a fire.
- " Do not permit any vibration approaching it directly.
- " Go through module specification carefully, ensure inputs, output connections are made with the specifications. Use standard cables for wiring.
- " Use Product under pollution degree 2 environment.

1.1. Safety Instruction

1.1.1. Symbols

<p>DANGER</p> 	<p>Identifies information about practices or circumstances that can cause an explosion in a hazardous environment, which may lead to personal injury or death property damage, or economic loss</p>
<p>IMPORTANT</p>	<p>Identifies information that is critical for successful application and understanding of the product</p>
<p>ATTENTION</p> 	<p>Identifies information about practices or circumstances that can lead to personal injury, property damage, or economic loss. Attentions help you to identity a hazard, avoid a hazard, and recognize the consequences</p>

1.1.2. Safety Notes

<p>DANGER</p> 	<p>The modules are equipped with electronic components that may be destroyed by electrostatic discharge. When handling the modules, ensure that the environment (persons, workplace and packing) is well grounded. Avoid touching conductive components, GBUS Pin.</p>
--	--

1.1.3. Certification

c-UL-us UL Listed Industrial Control Equipment, certified for U.S. and Canada

See UL File E235505

CE Certificate

EN 61000-6-2; Industrial Immunity

EN 61000-6-4; Industrial Emissions
Reach, RoHS (EU, CHINA)

2. Analog Input Module List

GT-Number	Description	ID
GT-4114	Analog Output 4 Channels, Current Output, 0~20mA, 12Bits	4114
GT-4154	Analog Output 4 Channels, Current Output, 0~20mA, 16Bits	4154
GT-4118	Analog Output 8 Channels, Current Output, 0~20mA, 12Bits	4118
GT-4158	Analog Output 8 Channels, Current Output, 0~20mA, 16Bits	4158
GT-4214	Analog Output 4 Channels, Current Output, 4~20mA, 12Bits	4214
GT-4254	Analog Output 4 Channels, Current Output, 4~20mA, 16Bits	4254
GT-4218	Analog Output 8 Channels, Current Output, 4~20mA, 12Bits	4218
GT-4258	Analog Output 8 Channels, Current Output, 4~20mA, 16Bits	4258

3. Specification

3.1. GT-4114

3.1.1. Wiring Diagram

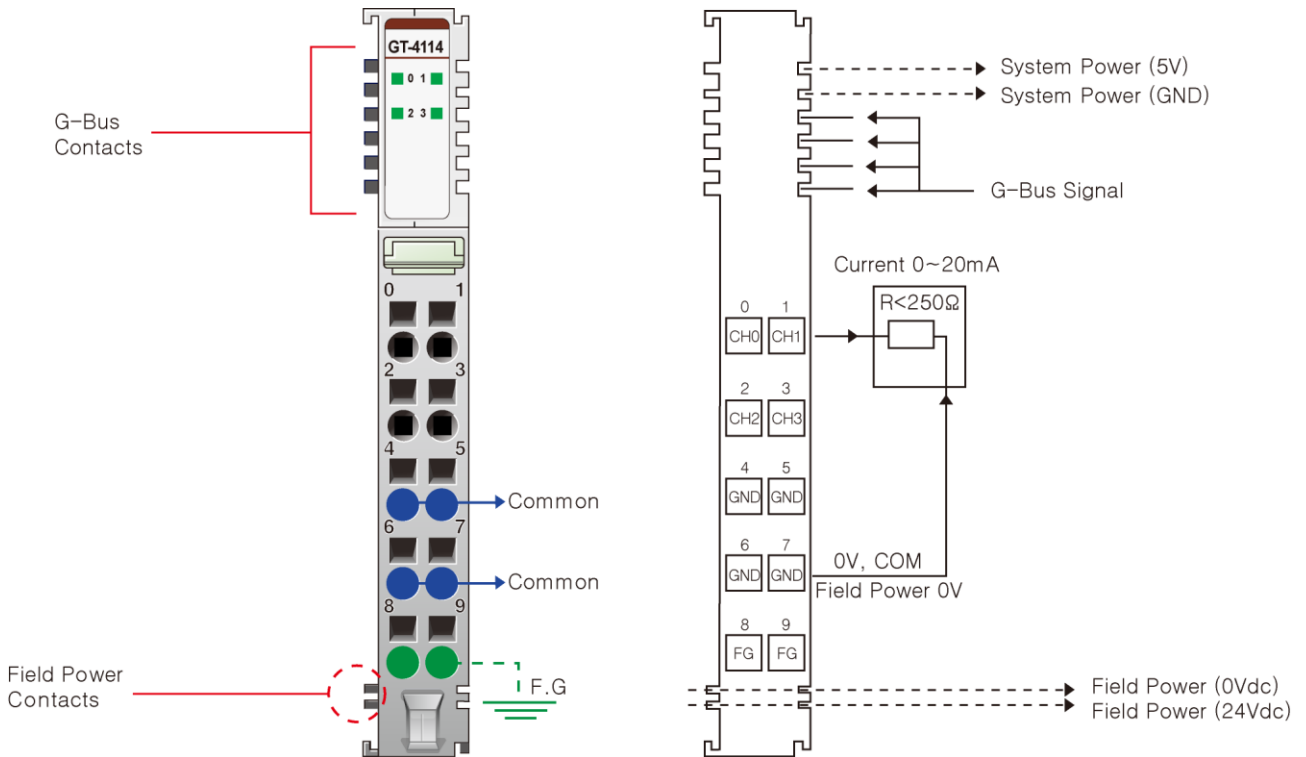

Pin No.	Signal Description	Signal Description	Pin No.
0	Analog Output Channel 0	Analog Output Channel 1	1
2	Analog Output Channel 2	Analog Output Channel 3	3
4	Output Channel Common(AGND)	Output Channel Common(AGND)	5
6	Output Channel Common(AGND)	Output Channel Common(AGND)	7
8	F.G	F.G	9

3.1.2. LED Indicator

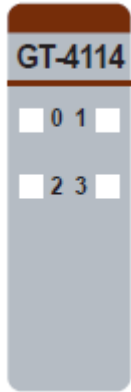

LED No.	LED Function / Description	LED Color
0	Output Channel 0	Green
1	Output Channel 1	Green
2	Output Channel 2	Green
3	Output Channel 3	Green

3.1.3. Channel Status LED

Status	LED	To indicate
Normal Operation	Off	No Output Value
	Green	Normal Operation
Field Power Error	All Channel Repeat Green and Off	Field Power is unconnected.

3.1.4. Environment Specification

Environmental Specification	
Operation Temperature	-40°C ~ 70°C
UL Temperature	-20°C ~60°C
Storage Temperature	-40°C ~85°C
Relative Humidity	5% ~ 90% Non-condensing
Mounting	DIN Rail
General Specification	
Shock Operating	IEC 60068-2-27 : 2008 / 15g, 11ms
Vibration Resistance	Based on IEC 60068-2-6 DNVGL-CG-0039 : Vibration Class B, 4g
Industrial Emissions	EN 61000-6-4/ All : 2011
Industrial Immunity	EN 61000-6-2 : 2005
Installation Position	Verical and horizontal installation is available
Product Cerifications	CE, UL, FCC

3.1.5. Specification

Items	Specification
Output Specification	
Outputs Per Module	4 Channels Single Ended, Non-Isolated Between Channel
Indicators(Logic side)	4 Green Output Status
Resolution in Ranges	12 Bits : 4.88uA/Bit
Output Range	0~20mA
Data Format	16 Bits Integer (2' compliment)
Module Error	±0.1% Full Scale @ 25°C ±0.3% Full Scale @ -40°C, 70°C
Load Resistance	Max. 250Ω*
Diagnostic	Field Power Off : LED Blinking Field Power On : No Output LED Off Field Power On : Output LED ON
Conversion Time	0.15msec / All Channel
Calibration	Not Required
Common Type	4 Channels / 4 Common
General Specification	
Power Dissipation	Max. 30mA @ 5.0Vdc
Isolation	I/O to Logic : Photocoupler Isolation Field Power : Non-Isolation
UL Field Power	Supply Voltage : 24Vdc nominal, Class 2
Field Power	Supply Voltage : 24Vdc nominal Voltage Range* : 18~30Vdc Power Dissipation : Max. 80mA @ 24Vdc
Wiring	I/O Cable Max. 2.0mm ² (AWG 14)
Torque	0.8Nm(7lb-in)
Weight	58g
Module Size	12mm x 99mm x 70mm
Environment Condition	Refer to 'Environment Specification'

* Operating temperature

- 40 ~ 70°C temperature range specification can be guaranteed under the following conditions.
- Load Resistance: Min 100Ω, Max 250Ω
- Field Power Voltage Range: Max 26.4V
- Otherwise, temperature specification can be guaranteed with -40 ~ 60°C

3.1.6. Data Value / Current

Current Range : 0~20mA

Current	0.0mA	5.0mA	10.0mA	20.0mA
Data(Hex)	H0000	H03FF	H07FF	H0FFF

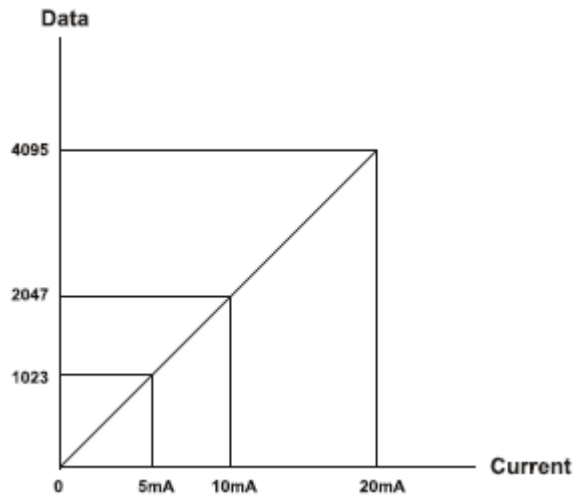

3.1.7. Mapping Data form the Image Table.

- Output Image Value

Bit No	Bit7	Bit6	Bit5	Bit4	Bit3	Bit2	Bit1	Bit0
Byte 0					Analog Output Ch0 Low byte			
Byte 1					Analog Output Ch0 High byte			
Byte 2					Analog Output Ch1 Low byte			
Byte 3					Analog Output Ch1 High byte			
Byte 4					Analog Output Ch2 Low byte			
Byte 5					Analog Output Ch2 High byte			
Byte 6					Analog Output Ch3 Low byte			
Byte 7					Analog Output Ch3 High byte			

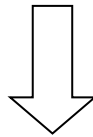

- Output Module Data - 8byte Output Data

Analog Input Ch0			
Analog Input Ch1			
Analog Input Ch2			
Analog Input Ch3			

3.1.8. Parameter Data

- Valid Parameter length : 4 Bytes

- Parameter Data

Bit No	Bit7	Bit6	Bit5	Bit4	Bit3	Bit2	Bit1	Bit0
Byte 0	Fault Action for Channel 3		Fault Action for Channel 2		Fault Action for Channel 1		Fault Action for Channel 0	
	00 : Fault Value 01 : Hold last state 10 : Low Limit 11 : high Limit							
Byte 1	Not used							
Byte 2	Fault Value Low Byte							
Byte 3	Not used				Fault Value high Byte			

3.2. GT-4154

3.2.1. Wiring Diagram

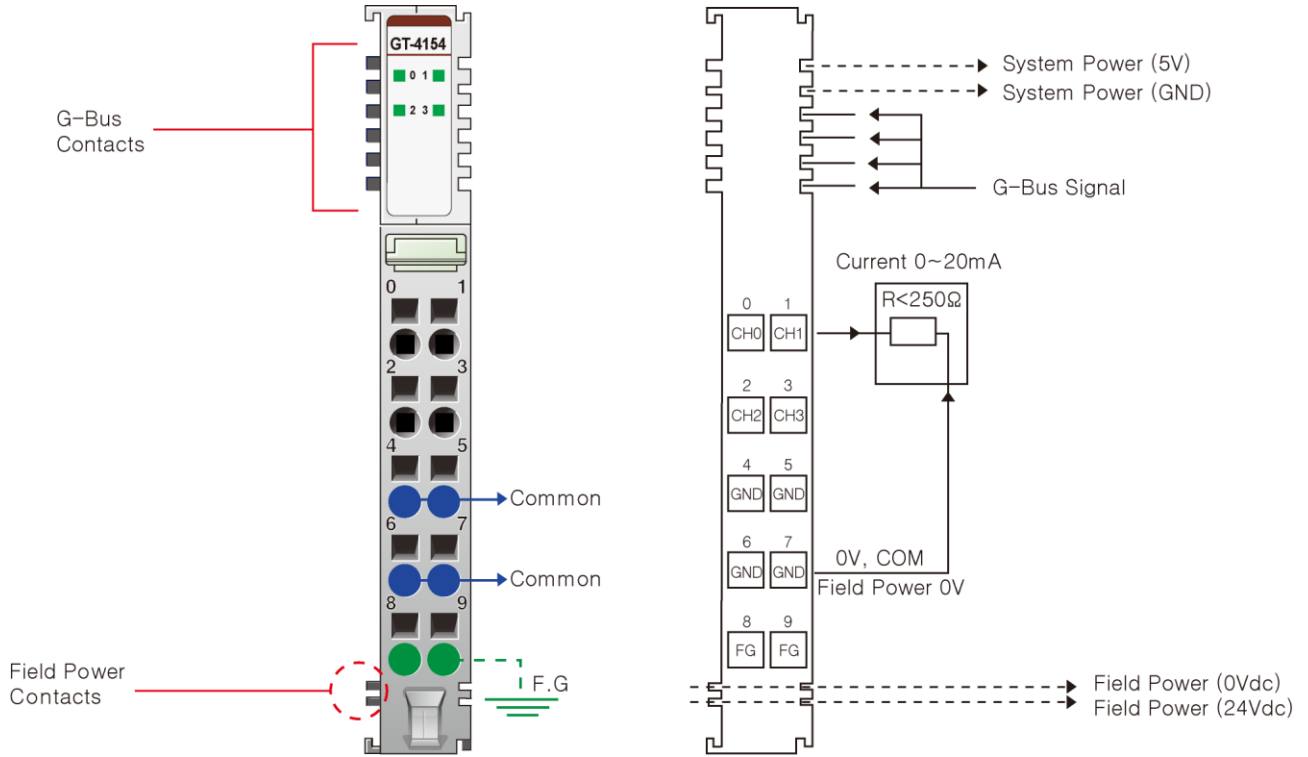

Pin No.	Signal Description	Signal Description	Pin No.
0	Analog Output Channel 0	Analog Output Channel 1	1
2	Analog Output Channel 2	Analog Output Channel 3	3
4	Output Channel Common(AGND)	Output Channel Common(AGND)	5
6	Output Channel Common(AGND)	Output Channel Common(AGND)	7
8	F.G	F.G	9

3.2.2. LED Indicator

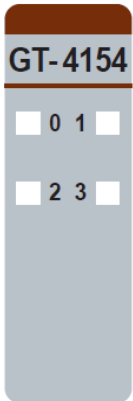

LED No.	LED Function / Description	LED Color
0	Output Channel 0	Green
1	Output Channel 1	Green
2	Output Channel 2	Green
3	Output Channel 3	Green

3.2.3. Channel Status LED

Status	LED	To indicate
Normal Operation	Off	No Output Value
	Green	Normal Operation
Field Power Error	All Channel Repeat Green and Off	Field Power is unconnected.

3.2.4. Environment Specification

Environmental Specification	
Operation Temperature	-40°C ~ 70°C
UL Temperature	-20°C ~60°C
Storage Temperature	-40°C ~85°C
Relative Humidity	5% ~ 90% Non-condensing
Mounting	DIN Rail
General Specification	
Shock Operating	IEC 60068-2-27 : 2008 / 15g, 11ms
Vibration Resistance	Based on IEC 60068-2-6 DNVGL-CG-0039 : Vibration Class B, 4g
Industrial Emissions	EN 61000-6-4/ All : 2011
Industrial Immunity	EN 61000-6-2 : 2005
Installation Position	Verical and horizontal installation is available
Product Cerifications	CE, UL, FCC

3.2.5. Specification

Items	Specification
Output Specification	
Outputs Per Module	4 Channels Single Ended, Non-Isolated Between Channel
Indicators(Logic side)	4 Green Output Status
Resolution in Ranges	16bit (Include Sign) 15bits : 0.61uA/bit
Output Range	0~20mA
Data Format	16 Bits Integer (2's compliment)
Module Error	±0.1% Full Scale @ 25°C ±0.3% Full Scale @ -40°C, 70°C
Load Resistance	Max. 250Ω*
Diagnostic	Field Power Off : LED Blinking Field Power On : No Output LED Off Field Power On : Output LED ON
Conversion Time	0.15msec / All Channel
Calibration	Not Required
Common Type	4 Channels / 4 Common
General Specification	
Power Dissipation	Max. 30mA @ 5.0Vdc
Isolation	I/O to Logic : Photocoupler Isolation Field Power : Non-Isolation
UL Field Power	Supply Voltage : 24Vdc nominal, Class 2
Field Power	Supply Voltage : 24Vdc nominal Voltage Range* : 18~30Vdc Power Dissipation : Max. 80mA @ 24Vdc
Wiring	I/O Cable Max. 2.0mm ² (AWG 14)
Torque	0.8Nm(7lb-in)
Weight	58g
Module Size	12mm x 99mm x 70mm
Environment Condition	Refer to 'Environment Specification'

* Operating temperature

- 40 ~ 70°C temperature range specification can be guaranteed under the following conditions.
- Load Resistance: Min 100Ω, Max 250Ω
- Field Power Voltage Range: Max 26.4V
- Otherwise, temperature specification can be guaranteed with -40 ~ 60°C

3.2.6. Data Value / Current

Current Range : 0~20mA

Current	0.0mA	5.0mA	10.0mA	20.0mA
Data(Hex)	H0000	H2000	H4000	H7FFF

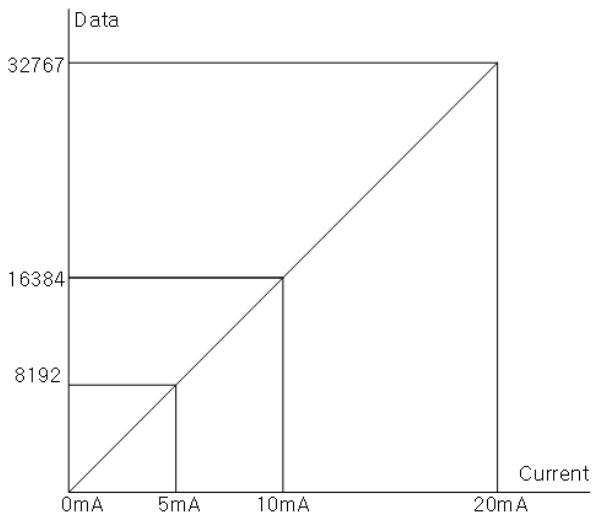

3.2.7. Mapping Data form the Image Table.

- Output Image Value

Bit No	Bit7	Bit6	Bit5	Bit4	Bit3	Bit2	Bit1	Bit0
Byte 0					Analog Output Ch0 Low byte			
Byte 1					Analog Output Ch0 High byte			
Byte 2					Analog Output Ch1 Low byte			
Byte 3					Analog Output Ch1 High byte			
Byte 4					Analog Output Ch2 Low byte			
Byte 5					Analog Output Ch2 High byte			
Byte 6					Analog Output Ch3 Low byte			
Byte 7					Analog Output Ch3 High byte			

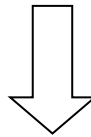

- Output Module Data - 8byte Output Data

Analog Input Ch0			
Analog Input Ch1			
Analog Input Ch2			
Analog Input Ch3			

3.2.8. Parameter Data

- Valid Parameter length : 4 Bytes

- Parameter Data

Bit No	Bit7	Bit6	Bit5	Bit4	Bit3	Bit2	Bit1	Bit0
Byte 0	Fault Action for Channel 3		Fault Action for Channel 2		Fault Action for Channel 1		Fault Action for Channel 0	
	00 : Fault Value 01 : Hold last state 10 : Low Limit 11 : high Limit							
Byte 1	Not used							
Byte 2	Fault Value Low Byte							
Byte 3	Fault Value high Byte							

3.3. GT-4118

3.3.1. Wiring Diagram

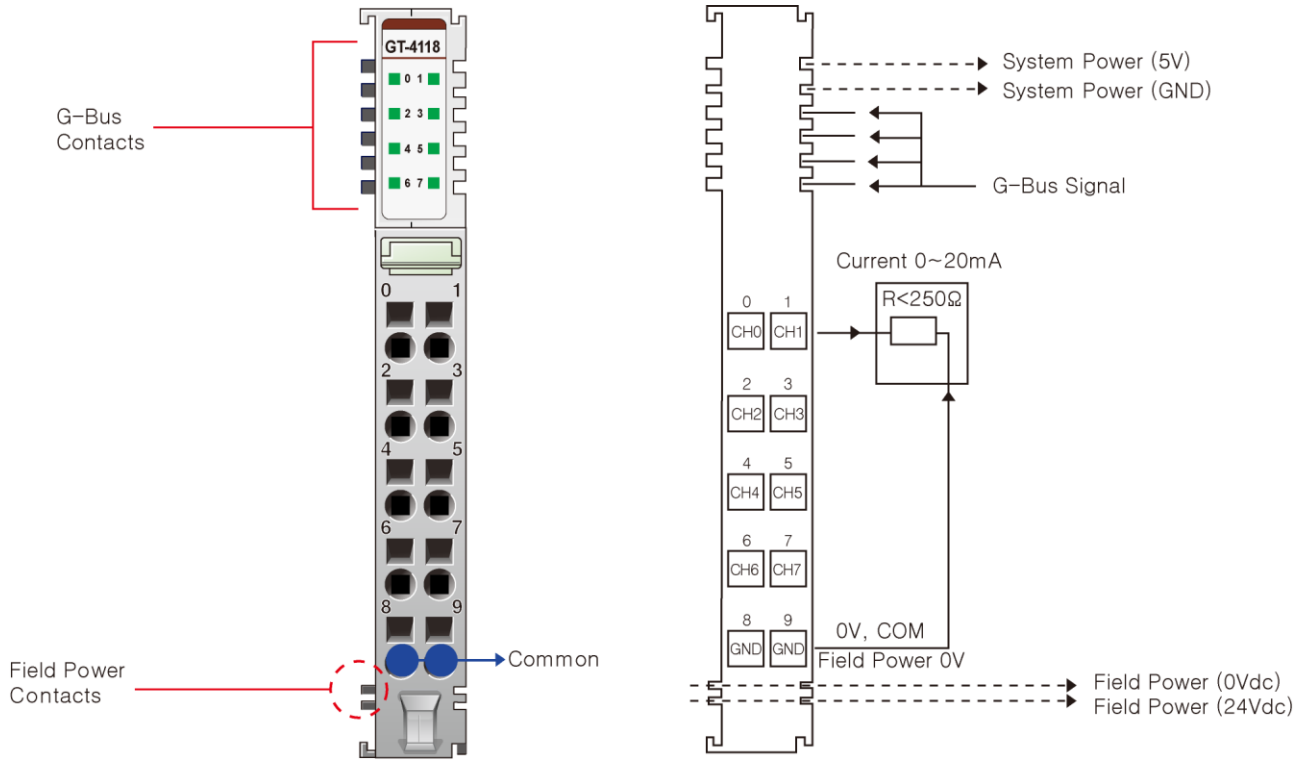

Pin No.	Signal Description	Signal Description	Pin No.
0	Analog Output Channel 0	Analog Output Channel 1	1
2	Analog Output Channel 2	Analog Output Channel 3	3
4	Analog Output Channel 4	Analog Output Channel 5	5
6	Analog Output Channel 6	Analog Output Channel 7	7
8	Output Channel Common(AGND)	Output Channel Common(AGND)	9

3.3.2. LED Indicator

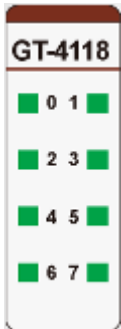

LED No.	LED Function / Description	LED Color
0	Output Channel 0	Green
1	Output Channel 1	Green
2	Output Channel 2	Green
3	Output Channel 3	Green
4	Output Channel 4	Green
5	Output Channel 5	Green
6	Output Channel 6	Green
7	Output Channel 7	Green

3.3.3. Channel Status LED

Status	LED	To indicate
Normal Operation	No Output Channel Off	No Output
	Output Channel Green	Output
Field Power Error	All Channel Repeat Green and Off	Field Power is unconnected.

3.3.4. Environment Specification

Environmental Specification	
Operation Temperature	-40°C ~ 60°C
UL Temperature	-20°C ~60°C
Storage Temperature	-40°C ~85°C
Relative Humidity	5% ~ 90% Non-condensing
Mounting	DIN Rail
General Specification	
Shock Operating	IEC 60068-2-27 : 2008 / 15g, 11ms
Vibration Resistance	Based on IEC 60068-2-6 DNVGL-CG-0039 : Vibration Class B, 4g
Industrial Emissions	EN 61000-6-4/ All : 2011
Industrial Immunity	EN 61000-6-2 : 2005
Installation Position	Verical and horizontal installation is available
Product Cerifications	CE, UL, FCC

3.3.5. Specification

Items	Specification
Output Specification	
Outputs Per Module	8 Channels Single Ended, Non-Isolated Between Channel
Indicators(Logic side)	8 Green Output Status
Resolution in Ranges	12 Bits : 4.88uA/Bit
Output Range	0~20mA
Data Format	16 Bits Integer (2' compliment)
Module Error	±0.1% Full Scale @ 25°C ±0.3% Full Scale @ -40°C, 60°C
Load Resistance	Max. 200Ω
Diagnostic	Field Power Off : LED Blinking Field Power On : No Output LED Off Field Power On : Output LED ON
Conversion Time	0.2msec / All Channel
Calibration	Not Required
Common Type	2 Common, Field Power 0V is Common(AGND)
General Specification	
Power Dissipation	Max. 30mA @ 5.0Vdc
Isolation	I/O to Logic : Photocoupler Isolation Field Power : Non-Isolation
UL Field Power	Supply Voltage : 24Vdc nominal, Class 2
Field Power	Supply Voltage : 24Vdc nominal Voltage Range : 18~30Vdc Power Dissipation : Max. 130mA @ 24Vdc
Wiring	I/O Cable Max. 2.0mm ² (AWG 14)
Torque	0.8Nm(7lb-in)
Weight	58g
Module Size	12mm x 99mm x 70mm
Environment Condition	Refer to 'Environment Specification'

3.3.6. Data Value / Current

Current Range : 0~20mA

Current	0.0mA	5.0mA	10.0mA	20.0mA
Data(Hex)	H0000	H2000	H4000	H7FFF

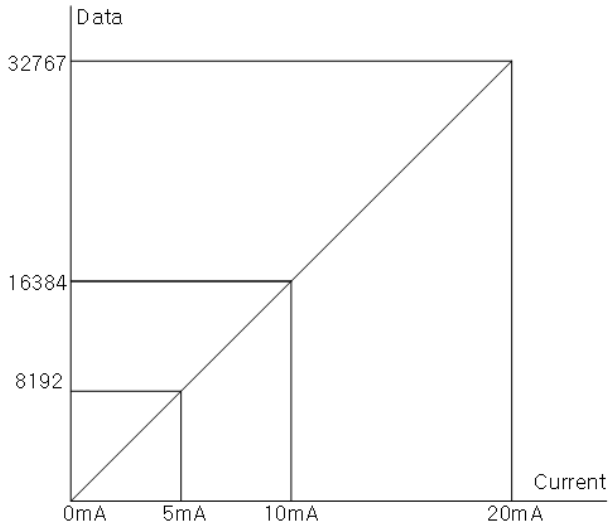

3.3.7. Mapping Data form the Image Table.

- Output Image Value

Bit No	Bit7	Bit6	Bit5	Bit4	Bit3	Bit2	Bit1	Bit0
Byte 0								Analog Output Ch0 Low byte
Byte 1								Analog Output Ch0 High byte
Byte 2								Analog Output Ch1 Low byte
Byte 3								Analog Output Ch1 High byte
Byte 4								Analog Output Ch2 Low byte
Byte 5								Analog Output Ch2 High byte
Byte 6								Analog Output Ch3 Low byte
Byte 7								Analog Output Ch3 High byte
Byte 8								Analog Output Ch4 Low byte
Byte 9								Analog Output Ch4 High byte
Byte 10								Analog Output Ch5 Low byte
Byte 11								Analog Output Ch5 High byte
Byte 12								Analog Output Ch6 Low byte
Byte 13								Analog Output Ch6 High byte
Byte 14								Analog Output Ch7 Low byte
Byte 15								Analog Output Ch7 High byte

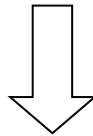

- Output Module Data - 16byte Output Data

Analog Input Ch0
Analog Input Ch1
Analog Input Ch2
Analog Input Ch3
Analog Input Ch4
Analog Input Ch5
Analog Input Ch6
Analog Input Ch7

3.3.8. Parameter Data

-. Valid Parameter length : 4 Bytes

-. Parameter Data

Bit No	Bit7	Bit6	Bit5	Bit4	Bit3	Bit2	Bit1	Bit0
Byte 0	Fault Action for Channel 3		Fault Action for Channel 2		Fault Action for Channel 1		Fault Action for Channel 0	
	00 : Fault Value 01 : Hold last state 10 : Low Limit 11 : high Limit							
Byte 1	Fault Action for Channel 7		Fault Action for Channel 6		Fault Action for Channel 5		Fault Action for Channel 4	
	00 : Fault Value 01 : Hold last state 10 : Low Limit 11 : high Limit							
Byte 2	Fault Value Low Byte							
Byte 3	Not used				Fault Value high Byte			

3.4. GT-4158

3.4.1. Wiring Diagram

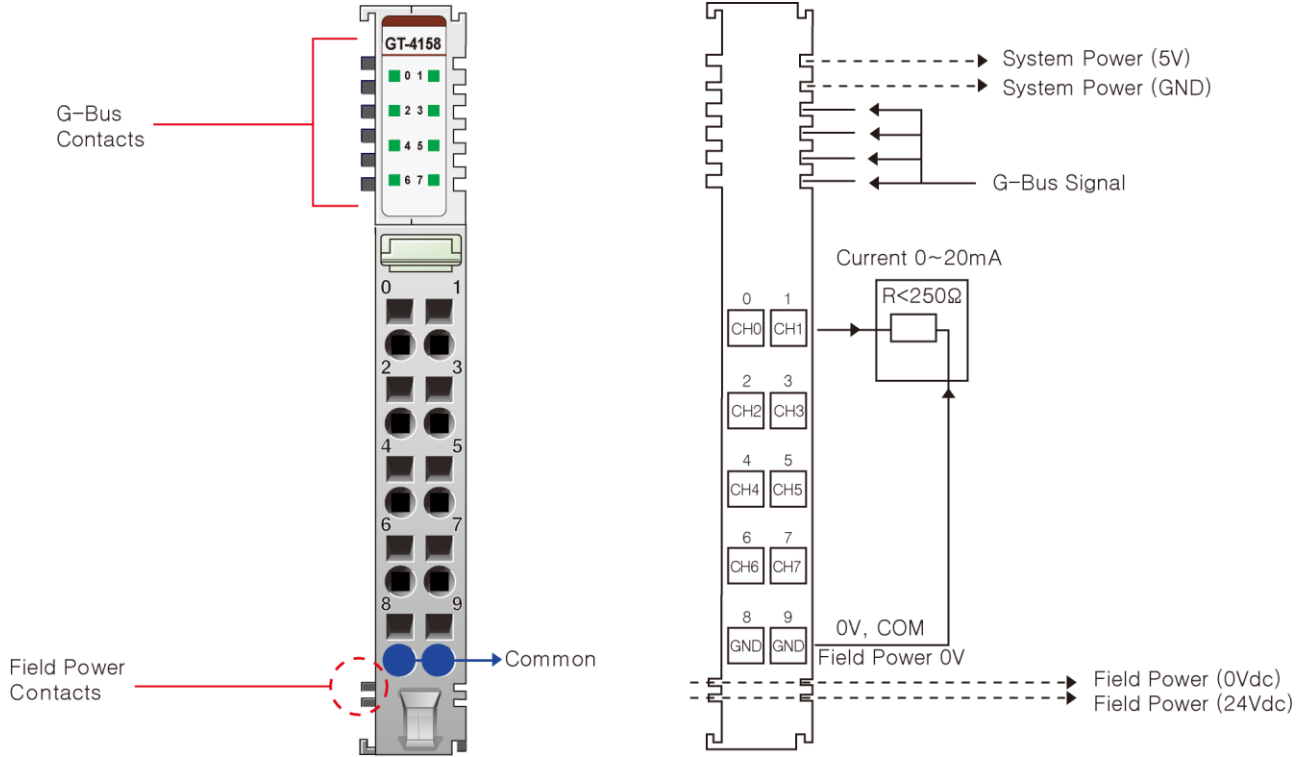

Pin No.	Signal Description	Signal Description	Pin No.
0	Analog Output Channel 0	Analog Output Channel 1	1
2	Analog Output Channel 2	Analog Output Channel 3	3
4	Analog Output Channel 4	Analog Output Channel 5	5
6	Analog Output Channel 6	Analog Output Channel 7	7
8	Output Channel Common(AGND)	Output Channel Common(AGND)	9

3.4.2. LED Indicator

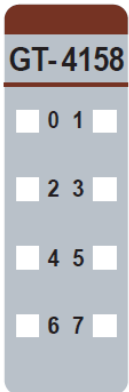

LED No.	LED Function / Description	LED Color
0	Output Channel 0	Green
1	Output Channel 1	Green
2	Output Channel 2	Green
3	Output Channel 3	Green
4	Output Channel 4	Green
5	Output Channel 5	Green
6	Output Channel 6	Green
7	Output Channel 7	Green

3.4.3. Channel Status LED

Status	LED	To indicate
Normal Operation	No Output Channel Off	No Output
	Output Channel Green	Output
Field Power Error	All Channel Repeat Green and Off	Field Power is unconnected.

3.4.4. Environment Specification

Environmental Specification	
Operation Temperature	-40°C ~ 60°C
UL Temperature	-20°C ~60°C
Storage Temperature	-40°C ~85°C
Relative Humidity	5% ~ 90% Non-condensing
Mounting	DIN Rail
General Specification	
Shock Operating	IEC 60068-2-27 : 2008 / 15g, 11ms
Vibration Resistance	Based on IEC 60068-2-6 DNVGL-CG-0039 : 2016 /6 Vibration Class B, 4g
Industrial Emissions	EN 61000-6-4/ All : 2011
Industrial Immunity	EN 61000-6-2 : 2005
Installation Position	Verical and horizontal installation is available
Product Cerifications	CE, UL, FCC

3.4.5. Specification

Items	Specification
Output Specification	
Outputs Per Module	8 Channels Single Ended, Non-Isolated Between Channel
Indicators(Logic side)	8 Green Output Status
Resolution in Ranges	16bit (Include Sign) 15bits : 0.61uA/bit
Output Range	0~20mA
Data Format	16 Bits Integer (2' compliment)
Module Error	±0.1% Full Scale @ 25°C ±0.3% Full Scale @ -40°C, 60°C
Load Resistance	Max. 200Ω
Diagnostic	Field Power Off : LED Blinking Field Power On : No Output LED Off Field Power On : Output LED ON
Conversion Time	0.2msec / All Channel
Calibration	Not Required
Common Type	2 Common, Field Power 0V is Common(AGND)
General Specification	
Power Dissipation	Max. 30mA @ 5.0Vdc
Isolation	I/O to Logic : Photocoupler Isolation Field Power : Non-Isolation
UL Field Power	Supply Voltage : 24Vdc nominal, Class 2
Field Power	Supply Voltage : 24Vdc nominal Voltage Range : 18~30Vdc Power Dissipation : Max. 80mA @ 24Vdc
Wiring	I/O Cable Max. 2.0mm ² (AWG 14)
Torque	0.8Nm(7lb-in)
Weight	58g
Module Size	12mm x 99mm x 70mm
Environment Condition	Refer to 'Environment Specification'

3.4.6. Data Value / Current

Current Range : 0~20mA

Current	0.0mA	5.0mA	10.0mA	20.0mA
Data(Hex)	H0000	H2000	H4000	H7FFF

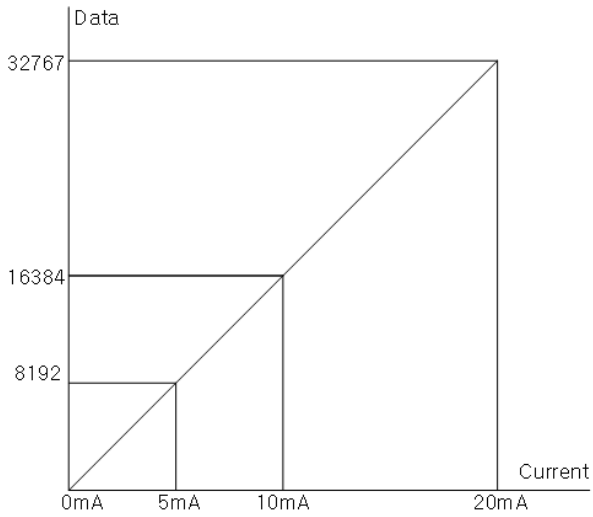

3.4.7. Mapping Data form the Image Table.

- Output Image Value

Bit No	Bit7	Bit6	Bit5	Bit4	Bit3	Bit2	Bit1	Bit0
Byte 0								Analog Output Ch0 Low byte
Byte 1								Analog Output Ch0 High byte
Byte 2								Analog Output Ch1 Low byte
Byte 3								Analog Output Ch1 High byte
Byte 4								Analog Output Ch2 Low byte
Byte 5								Analog Output Ch2 High byte
Byte 6								Analog Output Ch3 Low byte
Byte 7								Analog Output Ch3 High byte
Byte 8								Analog Output Ch4 Low byte
Byte 9								Analog Output Ch4 High byte
Byte 10								Analog Output Ch5 Low byte
Byte 11								Analog Output Ch5 High byte
Byte 12								Analog Output Ch6 Low byte
Byte 13								Analog Output Ch6 High byte
Byte 14								Analog Output Ch7 Low byte
Byte 15								Analog Output Ch7 High byte

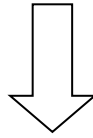

- Output Module Data - 16byte Output Data

	Analog Input Ch0
	Analog Input Ch1
	Analog Input Ch2
	Analog Input Ch3
	Analog Input Ch4
	Analog Input Ch5
	Analog Input Ch6
	Analog Input Ch7

3.4.8. Parameter Data

-. Valid Parameter length : 4 Bytes

-. Parameter Data

Bit No	Bit7	Bit6	Bit5	Bit4	Bit3	Bit2	Bit1	Bit0
Byte 0	Fault Action for Channel 3		Fault Action for Channel 2		Fault Action for Channel 1		Fault Action for Channel 0	
	00 : Fault Value 01 : Hold last state 10 : Low Limit 11 : high Limit							
Byte 1	Fault Action for Channel 7		Fault Action for Channel 6		Fault Action for Channel 5		Fault Action for Channel 4	
	00 : Fault Value 01 : Hold last state 10 : Low Limit 11 : high Limit							
Byte 2	Fault Value Low Byte							
Byte 3	Fault Value high Byte							

3.5. GT-4214

3.5.1. Wiring Diagram

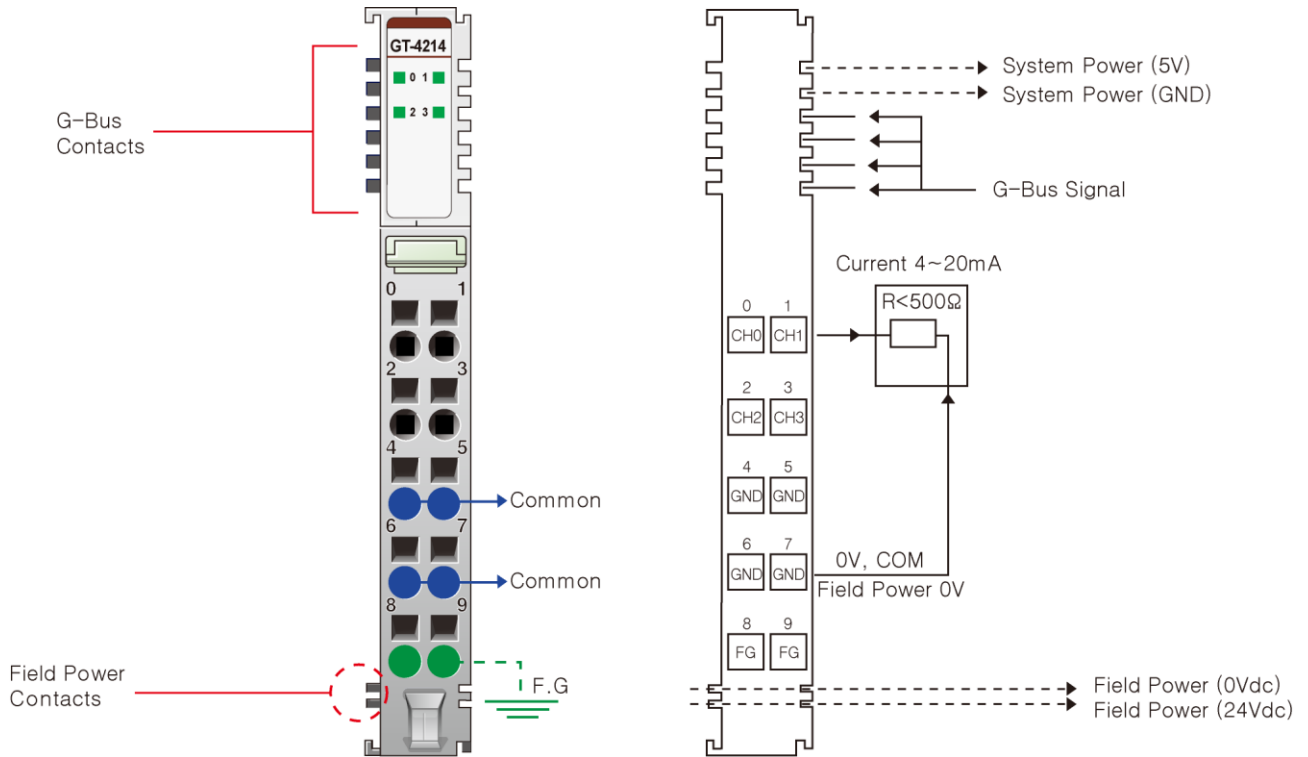

Pin No.	Signal Description	Signal Description	Pin No.
0	Analog Output Channel 0	Analog Output Channel 1	1
2	Analog Output Channel 2	Analog Output Channel 3	3
4	Output Channel Common(AGND)	Output Channel Common(AGND)	5
6	Output Channel Common(AGND)	Output Channel Common(AGND)	7
8	F.G	F.G	9

3.5.2. LED Indicator

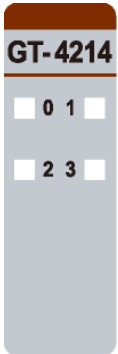

LED No.	LED Function / Description	LED Color
0	Output Channel 0	Green
1	Output Channel 1	Green
2	Output Channel 2	Green
3	Output Channel 3	Green

3.5.3. Channel Status LED

Status	LED	To indicate
Normal Operation	Green	Normal Operation
Field Power Error	All Channel Repeat Green and Off	Field Power is unconnected.

3.5.4. Environment Specification

Environmental Specification	
Operation Temperature	-40°C ~ 70°C
UL Temperature	-20°C ~60°C
Storage Temperature	-40°C ~85°C
Relative Humidity	5% ~ 90% Non-condensing
Mounting	DIN Rail
General Specification	
Shock Operating	IEC 60068-2-27 : 2008 / 15g, 11ms
Vibration Resistance	Based on IEC 60068-2-6 DNVGL-CG-0039 : Vibration Class B, 4g
Industrial Emissions	EN 61000-6-4/ All : 2011
Industrial Immunity	EN 61000-6-2 : 2005
Installation Position	Verical and horizontal installation is available
Product Cerifications	CE, UL, FCC

3.5.5. Specification

Items	Specification
Output Specification	
Outputs Per Module	4 Channels Single Ended, Non-Isolated Between Channel
Indicators(Logic side)	4 Green Output Status
Resolution in Ranges	12 Bits : 3.91uA/Bit
Output Range	4~20mA
Data Format	16 Bits Integer (2's compliment)
Module Error	±0.1% Full Scale @ 25°C ±0.3% Full Scale @ -40°C, 70°C
Load Resistance	Max. 250Ω*
Diagnostic	Field Power Off : LED Blinking Field Power On : Output LED ON
Conversion Time	0.15msec / All Channel
Calibration	Not Required
Common Type	4 Channels / 4 Common
General Specification	
Power Dissipation	Max. 30mA @ 5.0Vdc
Isolation	I/O to Logic : Photocoupler Isolation Field Power : Non-Isolation
UL Field Power	Supply Voltage : 24Vdc nominal, Class 2
Field Power	Supply Voltage : 24Vdc nominal Voltage Range* : 18~30Vdc Power Dissipation : Max. 80mA @ 24Vdc
Wiring	I/O Cable Max. 2.0mm ² (AWG 14)
Torque	0.8Nm(7lb-in)
Weight	58g
Module Size	12mm x 99mm x 70mm
Environment Condition	Refer to 'Environment Specification'

* Operating temperature

- 40 ~ 70°C temperature range specification can be guaranteed under the following conditions.
- Load Resistance: Min 100Ω, Max 250Ω
- Field Power Voltage Range: Max 26.4V
- Otherwise, temperature specification can be guaranteed with -40 ~ 60°C

3.5.6. Data Value / Current

Current Range : 4~20mA

Current	4.0mA	8.0mA	12.0mA	20.0mA
Data(Hex)	H0000	H0400	H0800	H0FFF

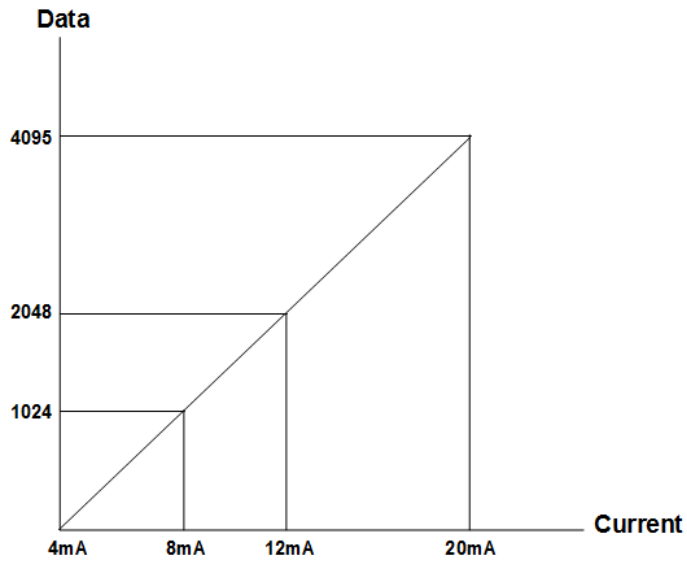

3.5.7. Mapping Data form the Image Table.

- Output Image Value

Bit No	Bit7	Bit6	Bit5	Bit4	Bit3	Bit2	Bit1	Bit0
Byte 0	Analog Output Ch0 Low byte							
Byte 1	Analog Output Ch0 High byte							
Byte 2	Analog Output Ch1 Low byte							
Byte 3	Analog Output Ch1 High byte							
Byte 4	Analog Output Ch2 Low byte							
Byte 5	Analog Output Ch2 High byte							
Byte 6	Analog Output Ch3 Low byte							
Byte 7	Analog Output Ch3 High byte							

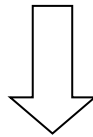

- Output Module Data - 8byte Output Data

Analog Input Ch0							
Analog Input Ch1							
Analog Input Ch2							
Analog Input Ch3							

3.5.8. Parameter Data

- Valid Parameter length : 4 Bytes

- Parameter Data

Bit No	Bit7	Bit6	Bit5	Bit4	Bit3	Bit2	Bit1	Bit0
Byte 0	Fault Action for Channel 3		Fault Action for Channel 2		Fault Action for Channel 1		Fault Action for Channel 0	
	00 : Fault Value 01 : Hold last state 10 : Low Limit 11 : high Limit							
Byte 1	Not used							
Byte 2	Fault Value Low Byte							
Byte 3	Not used				Fault Value high Byte			

3.6. GT-4254

3.6.1. Wiring Diagram

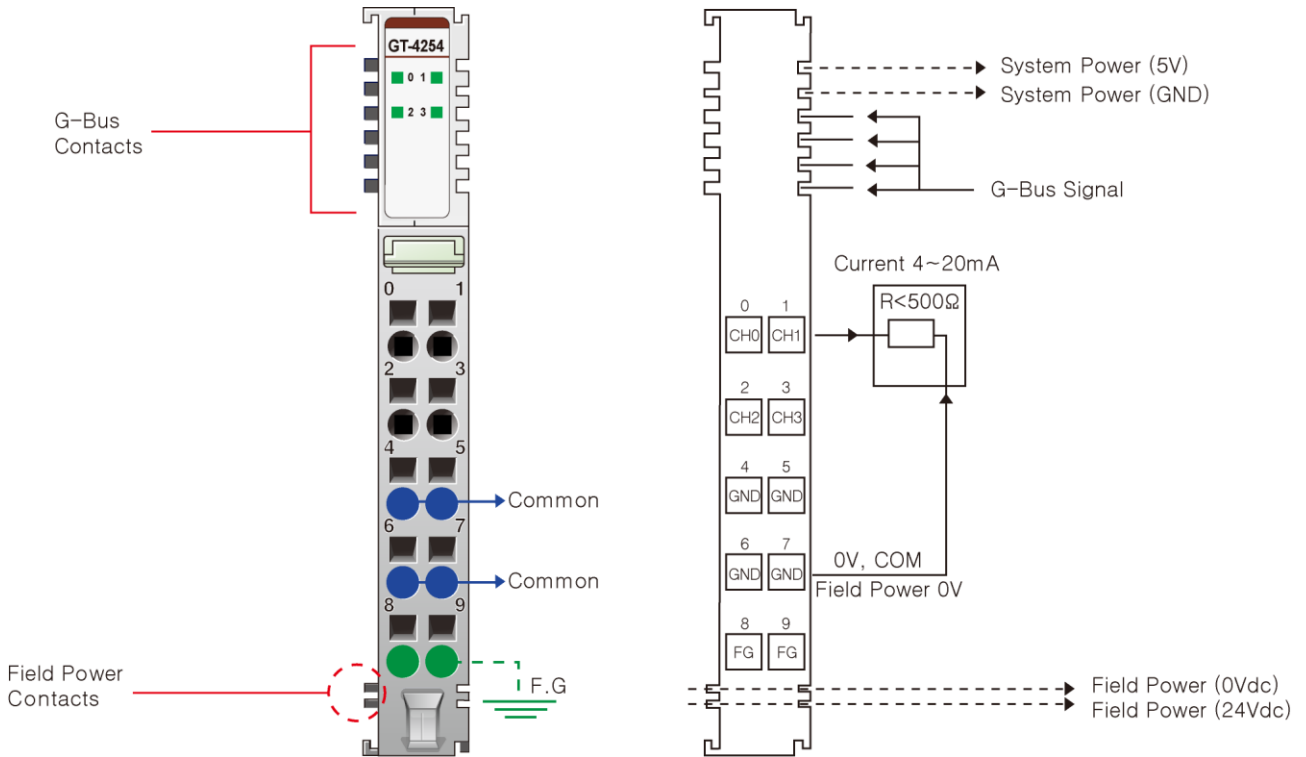

Pin No.	Signal Description	Signal Description	Pin No.
0	Analog Output Channel 0	Analog Output Channel 1	1
2	Analog Output Channel 2	Analog Output Channel 3	3
4	Output Channel Common(AGND)	Output Channel Common(AGND)	5
6	Output Channel Common(AGND)	Output Channel Common(AGND)	7
8	F.G	F.G	9

3.6.2. LED Indicator

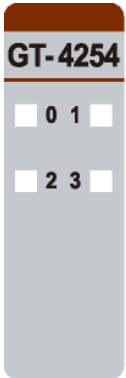

LED No.	LED Function / Description	LED Color
0	Output Channel 0	Green
1	Output Channel 1	Green
2	Output Channel 2	Green
3	Output Channel 3	Green

3.6.3. Channel Status LED

Status	LED	To indicate
Normal Operation	Green	Normal Operation
Field Power Error	All Channel Repeat Green and Off	Field Power is unconnected.

3.6.4. Environment Specification

Environmental Specification	
Operation Temperature	-40°C ~ 70°C
UL Temperature	-20°C ~60°C
Storage Temperature	-40°C ~85°C
Relative Humidity	5% ~ 90% Non-condensing
Mounting	DIN Rail
General Specification	
Shock Operating	IEC 60068-2-27 : 2008 / 15g, 11ms
Vibration Resistance	Based on IEC 60068-2-6 DNVGL-CG-0039 : Vibration Class B, 4g
Industrial Emissions	EN 61000-6-4/ All : 2011
Industrial Immunity	EN 61000-6-2 : 2005
Installation Position	Verical and horizontal installation is available
Product Cerifications	CE, UL, FCC

3.6.5. Specification

Items	Specification
Output Specification	
Outputs Per Module	4 Channels Single Ended, Non-Isolated Between Channel
Indicators(Logic side)	4 Green Output Status
Resolution in Ranges	16bit (Include Sign) 15bits : 0.49uA/bit
Output Range	4~20mA
Data Format	16 Bits Integer (2's compliment)
Module Error	±0.1% Full Scale @ 25°C ±0.3% Full Scale @ -40°C, 70°C
Load Resistance	Max. 250Ω*
Diagnostic	Field Power Off : LED Blinking Field Power On : Output LED ON
Conversion Time	0.15msec / All Channel
Calibration	Not Required
Common Type	4 Channels / 4 Common
General Specification	
Power Dissipation	Max. 30mA @ 5.0Vdc
Isolation	I/O to Logic : Photocoupler Isolation Field Power : Non-Isolation
UL Field Power	Supply Voltage : 24Vdc nominal, Class 2
Field Power	Supply Voltage : 24Vdc nominal Voltage Range* : 18~30Vdc Power Dissipation : Max. 80mA @ 24Vdc
Wiring	I/O Cable Max. 2.0mm ² (AWG 14)
Torque	0.8Nm(7lb-in)
Weight	58g
Module Size	12mm x 99mm x 70mm
Environment Condition	Refer to 'Environment Specification'

* Operating temperature

- 40 ~ 70°C temperature range specification can be guaranteed under the following conditions.

- Load Resistance: Min 100Ω, Max 250Ω

- Field Power Voltage Range: Max 26.4V

- Otherwise, temperature specification can be guaranteed with -40 ~ 60°C

3.6.6. Data Value / Current

Current Range : 4~20mA

Current	4.0mA	8.0mA	12.0mA	20.0mA
Data(Hex)	H0000	H2000	H4000	H7FFF

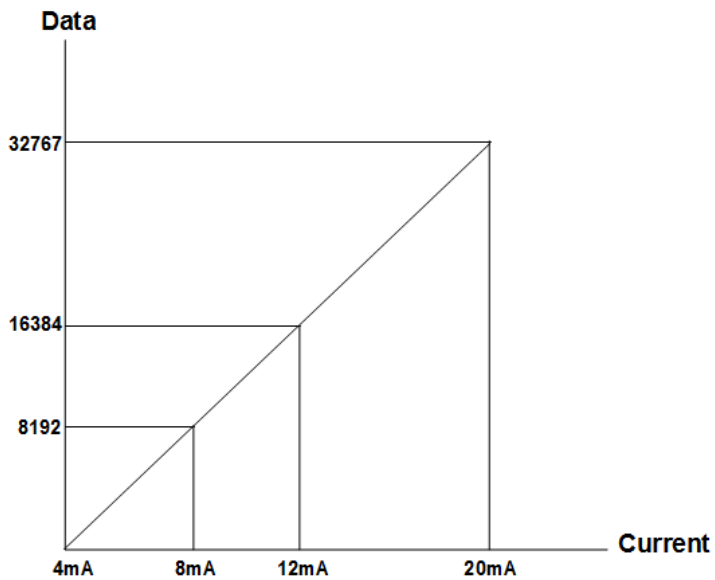

3.6.7. Mapping Data form the Image Table.

- Output Image Value

Bit No	Bit7	Bit6	Bit5	Bit4	Bit3	Bit2	Bit1	Bit0
Byte 0	Analog Output Ch0 Low byte							
Byte 1	Analog Output Ch0 High byte							
Byte 2	Analog Output Ch1 Low byte							
Byte 3	Analog Output Ch1 High byte							
Byte 4	Analog Output Ch2 Low byte							
Byte 5	Analog Output Ch2 High byte							
Byte 6	Analog Output Ch3 Low byte							
Byte 7	Analog Output Ch3 High byte							

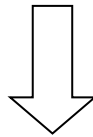

- Output Module Data - 8byte Output Data

Analog Input Ch0							
Analog Input Ch1							
Analog Input Ch2							
Analog Input Ch3							

3.6.8. Parameter Data

- Valid Parameter length : 4 Bytes

- Parameter Data

Bit No	Bit7	Bit6	Bit5	Bit4	Bit3	Bit2	Bit1	Bit0
Byte 0	Fault Action for Channel 3		Fault Action for Channel 2		Fault Action for Channel 1		Fault Action for Channel 0	
	00 : Fault Value 01 : Hold last state 10 : Low Limit 11 : high Limit							
Byte 1	Not used							
Byte 2	Fault Value Low Byte							
Byte 3	Fault Value high Byte							

3.7. GT-4218

3.7.1. Wiring Diagram

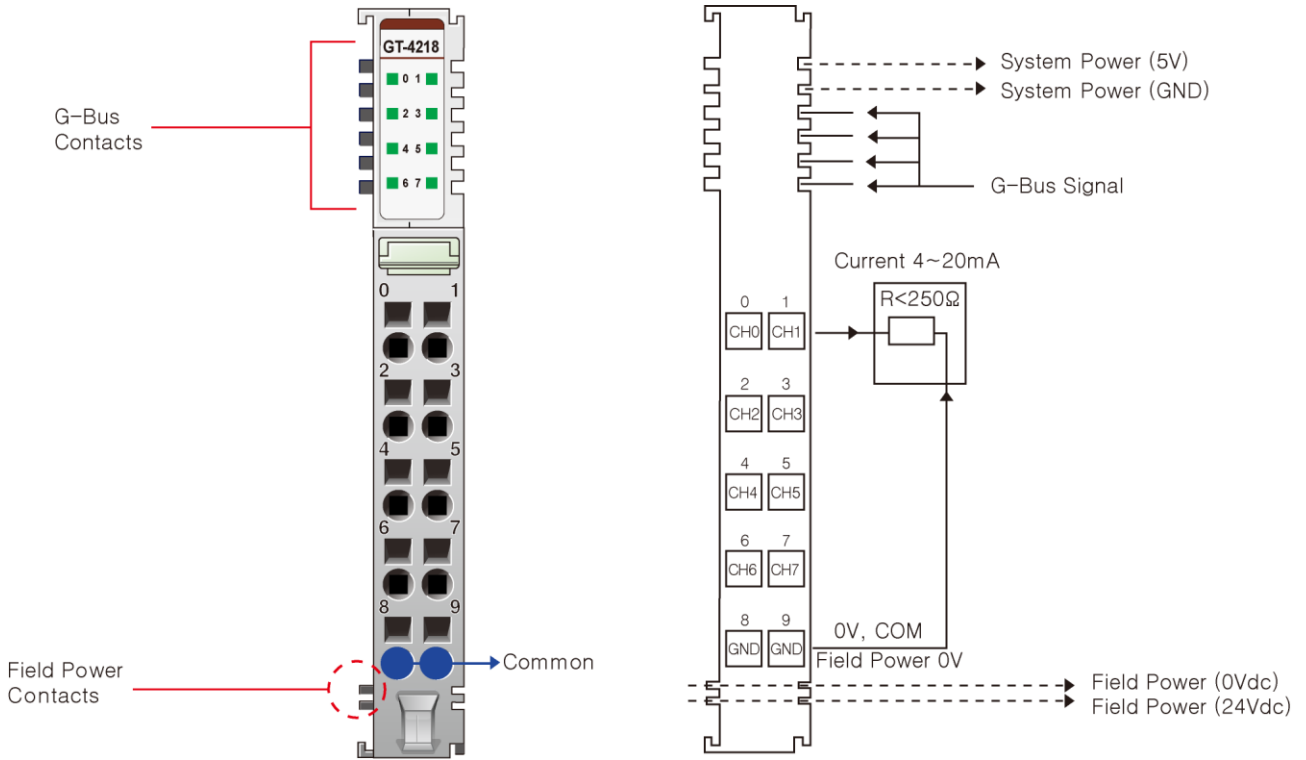

Pin No.	Signal Description	Signal Description	Pin No.
0	Analog Output Channel 0	Analog Output Channel 1	1
2	Analog Output Channel 2	Analog Output Channel 3	3
4	Analog Output Channel 4	Analog Output Channel 5	5
6	Analog Output Channel 6	Analog Output Channel 7	7
8	Output Channel Common(AGND)	Output Channel Common(AGND)	9

3.7.2. LED Indicator

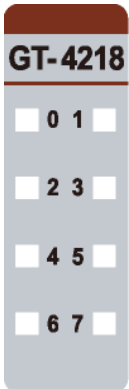

LED No.	LED Function / Description	LED Color
0	Output Channel 0	Green
1	Output Channel 1	Green
2	Output Channel 2	Green
3	Output Channel 3	Green
4	Output Channel 4	Green
5	Output Channel 5	Green
6	Output Channel 6	Green
7	Output Channel 7	Green

3.7.3. Channel Status LED

Status	LED	To indicate
Normal Operation	Green	Normal Operation
Field Power Error	All Channel Repeat Green and Off	Field Power is unconnected.

3.7.4. Environment Specification

Environmental Specification	
Operation Temperature	-40°C ~ 60°C
UL Temperature	-20°C ~60°C
Storage Temperature	-40°C ~85°C
Relative Humidity	5% ~ 90% Non-condensing
Mounting	DIN Rail
General Specification	
Shock Operating	IEC 60068-2-27 : 2008 / 15g, 11ms
Vibration Resistance	Based on IEC 60068-2-6 DNVGL-CG-0039 : Vibration Class B, 4g
Industrial Emissions	EN 61000-6-4/ All : 2011
Industrial Immunity	EN 61000-6-2 : 2005
Installation Position	Verical and horizontal installation is available
Product Cerifications	CE, UL, FCC

3.7.5. Specification

Items	Specification
Output Specification	
Outputs Per Module	8 Channels Single Ended, Non-Isolated Between Channel
Indicators(Logic side)	8 Green Output Status
Resolution in Ranges	12 Bits : 3.91uA/Bit
Output Range	4~20mA
Data Format	16 Bits Integer (2' compliment)
Module Error	±0.1% Full Scale @ 25°C ±0.3% Full Scale @ -40°C, 60°C
Load Resistance	Max. 200Ω
Diagnostic	Field Power Off : LED Blinking Field Power On : Output LED ON
Conversion Time	0.2msec / All Channel
Calibration	Not Required
Common Type	2 Common, Field Power 0V is Common(AGND)
General Specification	
Power Dissipation	Max. 30mA @ 5.0Vdc
Isolation	I/O to Logic : Photocoupler Isolation Field Power : Non-Isolation
UL Field Power	Supply Voltage : 24Vdc nominal, Class 2
Field Power	Supply Voltage : 24Vdc nominal Voltage Range : 18~30Vdc Power Dissipation : Max. 130mA @ 24Vdc
Wiring	I/O Cable Max. 2.0mm ² (AWG 14)
Torque	0.8Nm(7lb-in)
Weight	58g
Module Size	12mm x 99mm x 70mm
Environment Condition	Refer to 'Environment Specification'

3.7.6. Data Value / Current

Current Range : 4~20mA

Current	4.0mA	8.0mA	12.0mA	20.0mA
Data(Hex)	H0000	H0400	H0800	H0FFF

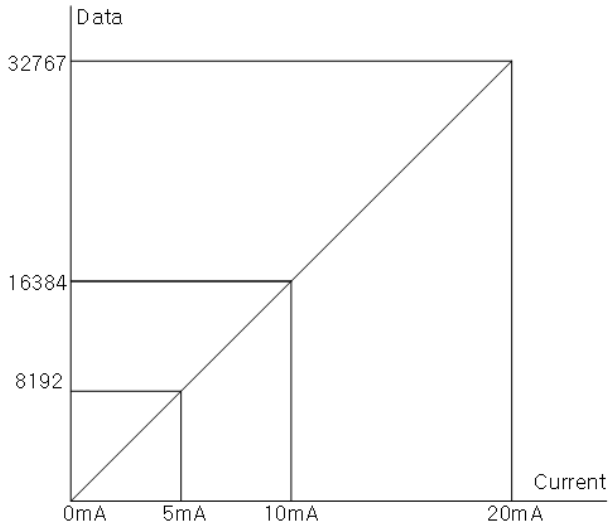

3.7.7. Mapping Data form the Image Table.

- Output Image Value

Bit No	Bit7	Bit6	Bit5	Bit4	Bit3	Bit2	Bit1	Bit0
Byte 0	Analog Output Ch0 Low byte							
Byte 1	Analog Output Ch0 High byte							
Byte 2	Analog Output Ch1 Low byte							
Byte 3	Analog Output Ch1 High byte							
Byte 4	Analog Output Ch2 Low byte							
Byte 5	Analog Output Ch2 High byte							
Byte 6	Analog Output Ch3 Low byte							
Byte 7	Analog Output Ch3 High byte							
Byte 8	Analog Output Ch4 Low byte							
Byte 9	Analog Output Ch4 High byte							
Byte 10	Analog Output Ch5 Low byte							
Byte 11	Analog Output Ch5 High byte							
Byte 12	Analog Output Ch6 Low byte							
Byte 13	Analog Output Ch6 High byte							
Byte 14	Analog Output Ch7 Low byte							
Byte 15	Analog Output Ch7 High byte							

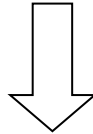

- Output Module Data - 16byte Output Data

Analog Input Ch0
Analog Input Ch1
Analog Input Ch2
Analog Input Ch3
Analog Input Ch4
Analog Input Ch5
Analog Input Ch6
Analog Input Ch7

3.7.8. Parameter Data

-. Valid Parameter length : 4 Bytes

-. Parameter Data

Bit No	Bit7	Bit6	Bit5	Bit4	Bit3	Bit2	Bit1	Bit0
Byte 0	Fault Action for Channel 3		Fault Action for Channel 2		Fault Action for Channel 1		Fault Action for Channel 0	
	00 : Fault Value 01 : Hold last state 10 : Low Limit 11 : high Limit							
Byte 1	Fault Action for Channel 7		Fault Action for Channel 6		Fault Action for Channel 5		Fault Action for Channel 4	
	00 : Fault Value 01 : Hold last state 10 : Low Limit 11 : high Limit							
Byte 2	Fault Value Low Byte							
Byte 3	Not used				Fault Value high Byte			

3.8. GT-4258

3.8.1. Wiring Diagram

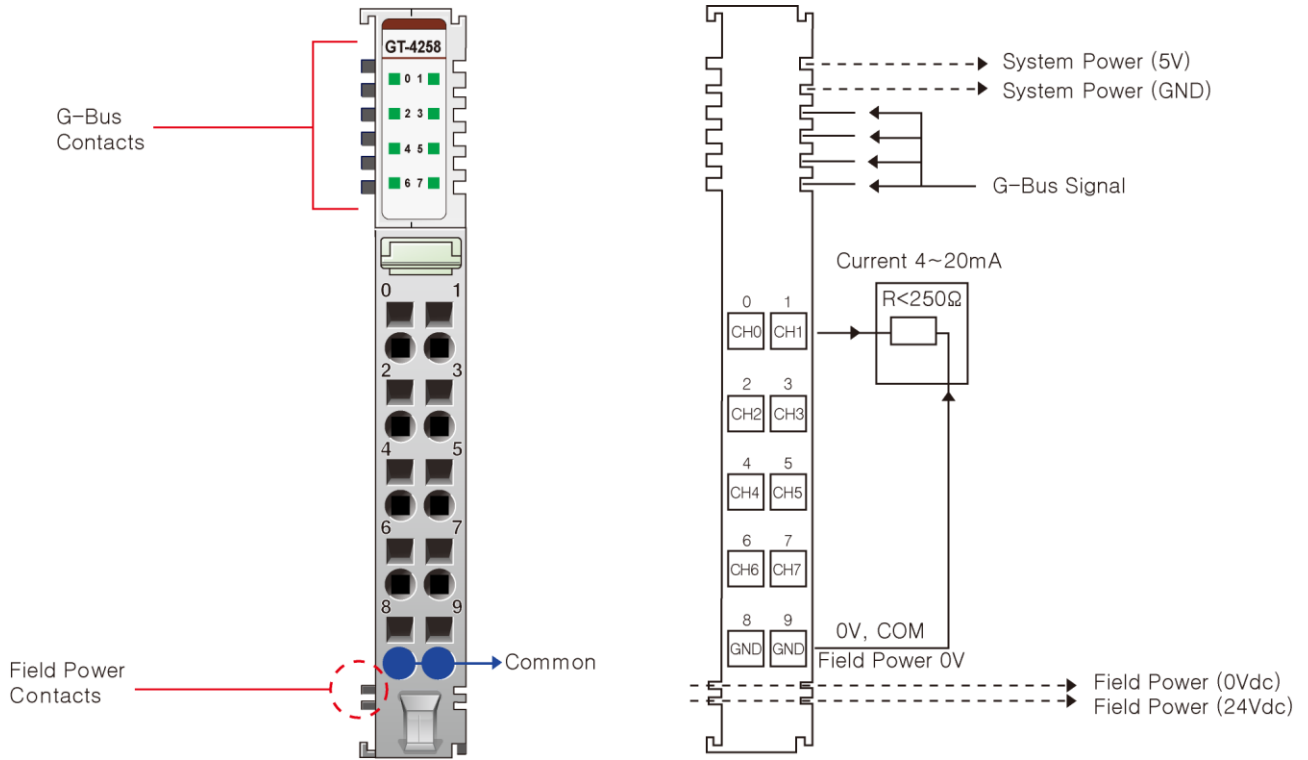

Pin No.	Signal Description	Signal Description	Pin No.
0	Analog Output Channel 0	Analog Output Channel 1	1
2	Analog Output Channel 2	Analog Output Channel 3	3
4	Analog Output Channel 4	Analog Output Channel 5	5
6	Analog Output Channel 6	Analog Output Channel 7	7
8	Output Channel Common(AGND)	Output Channel Common(AGND)	9

3.8.2. LED Indicator

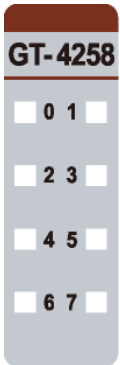

LED No.	LED Function / Description	LED Color
0	Output Channel 0	Green
1	Output Channel 1	Green
2	Output Channel 2	Green
3	Output Channel 3	Green
4	Output Channel 4	Green
5	Output Channel 5	Green
6	Output Channel 6	Green
7	Output Channel 7	Green

3.8.3. Channel Status LED

Status	LED	To indicate
Normal Operation	Green	Normal Operation
Field Power Error	All Channel Repeat Green and Off	Field Power is unconnected.

3.8.4. Environment Specification

Environmental Specification	
Operation Temperature	-40°C ~ 60°C
UL Temperature	-20°C ~60°C
Storage Temperature	-40°C ~85°C
Relative Humidity	5% ~ 90% Non-condensing
Mounting	DIN Rail
General Specification	
Shock Operating	IEC 60068-2-27 : 2008 / 15g, 11ms
Vibration Resistance	Based on IEC 60068-2-6 DNVGL-CG-0039 : Vibration Class B, 4g
Industrial Emissions	EN 61000-6-4/ All : 2011
Industrial Immunity	EN 61000-6-2 : 2005
Installation Position	Verical and horizontal installation is available
Product Cerifications	CE, UL, FCC

3.8.5. Specification

Items	Specification
Output Specification	
Outputs Per Module	8 Channels Single Ended, Non-Isolated Between Channel
Indicators(Logic side)	8 Green Output Status
Resolution in Ranges	16bit (Include Sign) 15bits : 0.49uA/bit
Output Range	4~20mA
Data Format	16 Bits Integer (2' compliment)
Module Error	±0.1% Full Scale @ 25°C ±0.3% Full Scale @ -40°C, 60°C
Load Resistance	Max. 200Ω
Diagnostic	Field Power Off : LED Blinking Field Power On : Output LED ON
Conversion Time	0.2msec / All Channel
Calibration	Not Required
Common Type	2 Common, Field Power 0V is Common(AGND)
General Specification	
Power Dissipation	Max. 30mA @ 5.0Vdc
Isolation	I/O to Logic : Photocoupler Isolation Field Power : Non-Isolation
UL Field Power	Supply Voltage : 24Vdc nominal, Class 2
Field Power	Supply Voltage : 24Vdc nominal Voltage Range : 18~30Vdc Power Dissipation : Max. 85mA @ 24Vdc
Wiring	I/O Cable Max. 2.0mm ² (AWG 14)
Torque	0.8Nm(7lb-in)
Weight	58g
Module Size	12mm x 99mm x 70mm
Environment Condition	Refer to 'Environment Specification'

3.8.6. Data Value / Current

Current Range : 4~20mA

Current	4.0mA	8.0mA	12.0mA	20.0mA
Data(Hex)	H0000	H2000	H4000	H7FFF

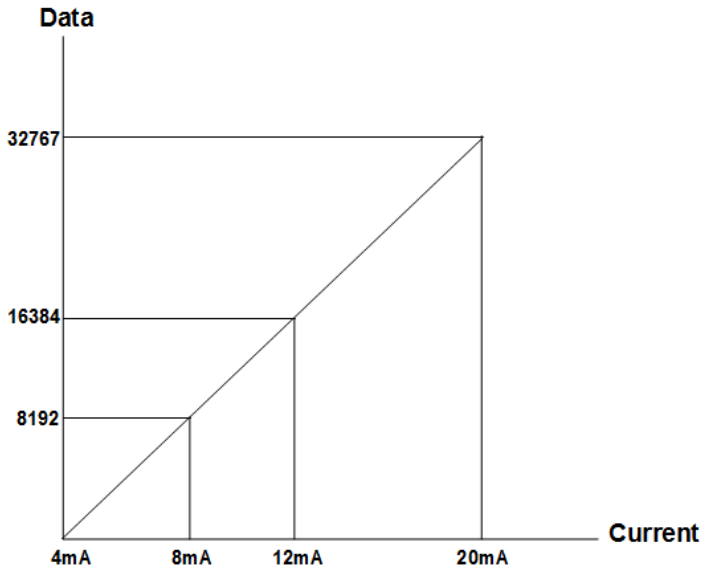

3.8.7. Mapping Data form the Image Table.

- Output Image Value

Bit No	Bit7	Bit6	Bit5	Bit4	Bit3	Bit2	Bit1	Bit0
Byte 0	Analog Output Ch0 Low byte							
Byte 1	Analog Output Ch0 High byte							
Byte 2	Analog Output Ch1 Low byte							
Byte 3	Analog Output Ch1 High byte							
Byte 4	Analog Output Ch2 Low byte							
Byte 5	Analog Output Ch2 High byte							
Byte 6	Analog Output Ch3 Low byte							
Byte 7	Analog Output Ch3 High byte							
Byte 8	Analog Output Ch4 Low byte							
Byte 9	Analog Output Ch4 High byte							
Byte 10	Analog Output Ch5 Low byte							
Byte 11	Analog Output Ch5 High byte							
Byte 12	Analog Output Ch6 Low byte							
Byte 13	Analog Output Ch6 High byte							
Byte 14	Analog Output Ch7 Low byte							
Byte 15	Analog Output Ch7 High byte							

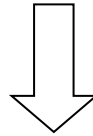

- Output Module Data - 8byte Output Data

Analog Input Ch0
Analog Input Ch1
Analog Input Ch2
Analog Input Ch3
Analog Input Ch4
Analog Input Ch5
Analog Input Ch6
Analog Input Ch7

3.8.8. Parameter Data

-. Valid Parameter length : 4 Bytes

-. Parameter Data

Bit No	Bit7	Bit6	Bit5	Bit4	Bit3	Bit2	Bit1	Bit0
Byte 0	Fault Action for Channel 3		Fault Action for Channel 2		Fault Action for Channel 1		Fault Action for Channel 0	
	00 : Fault Value 01 : Hold last state 10 : Low Limit 11 : high Limit							
Byte 1	Fault Action for Channel 7		Fault Action for Channel 6		Fault Action for Channel 5		Fault Action for Channel 4	
	00 : Fault Value 01 : Hold last state 10 : Low Limit 11 : high Limit							
Byte 2	Fault Value Low Byte							
Byte 3	Fault Value high Byte							

4. Dimension

4.1 GT-4xx4, GT-4xx8

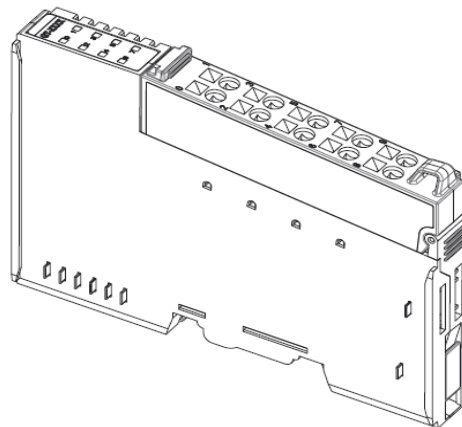
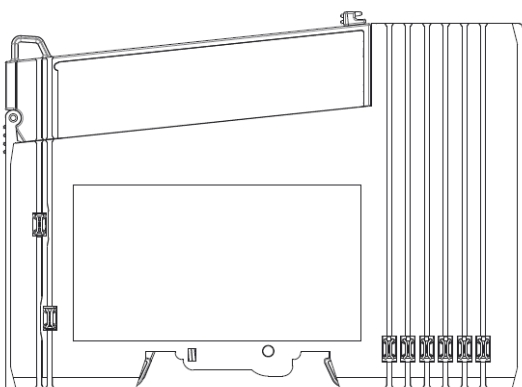
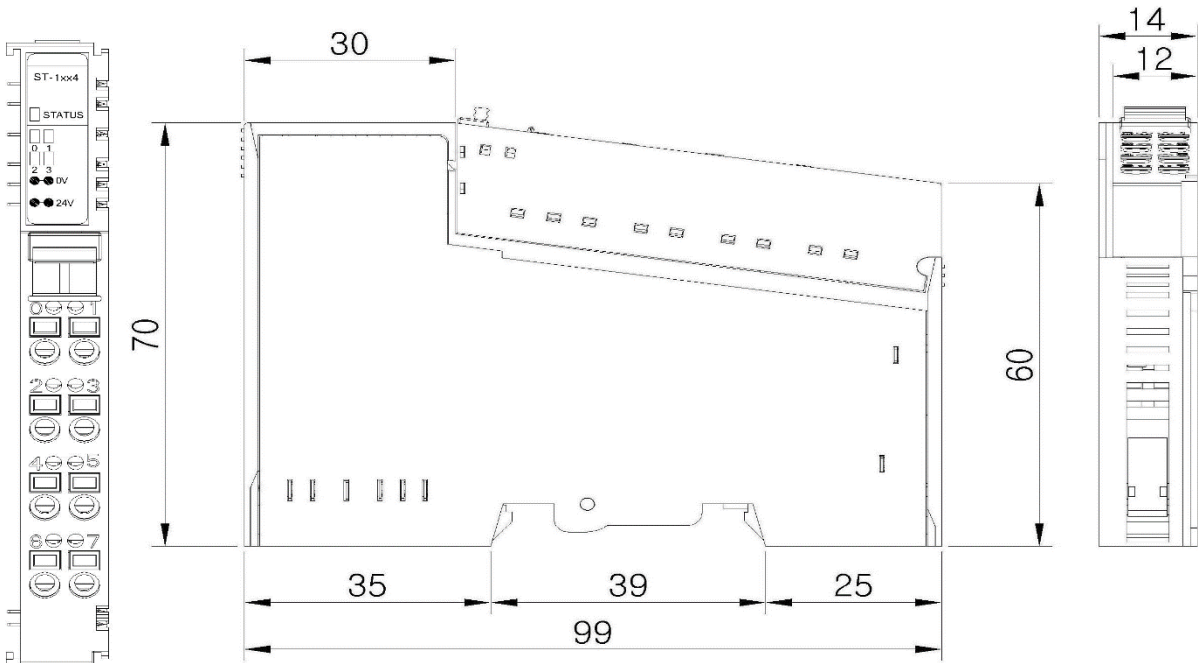

5. Mounting

" Hot surface!

The surface of the housing can become hot during operation. If the device was operated at high ambient temperatures, allow it to be cool before touching it.

Notice!

" Perform work on devices only if they are de-energized!

Working on energized devices can damage them. Therefore, turn off the power supply before working on the devices.

5.1 I/O Inserting and Removing Devices

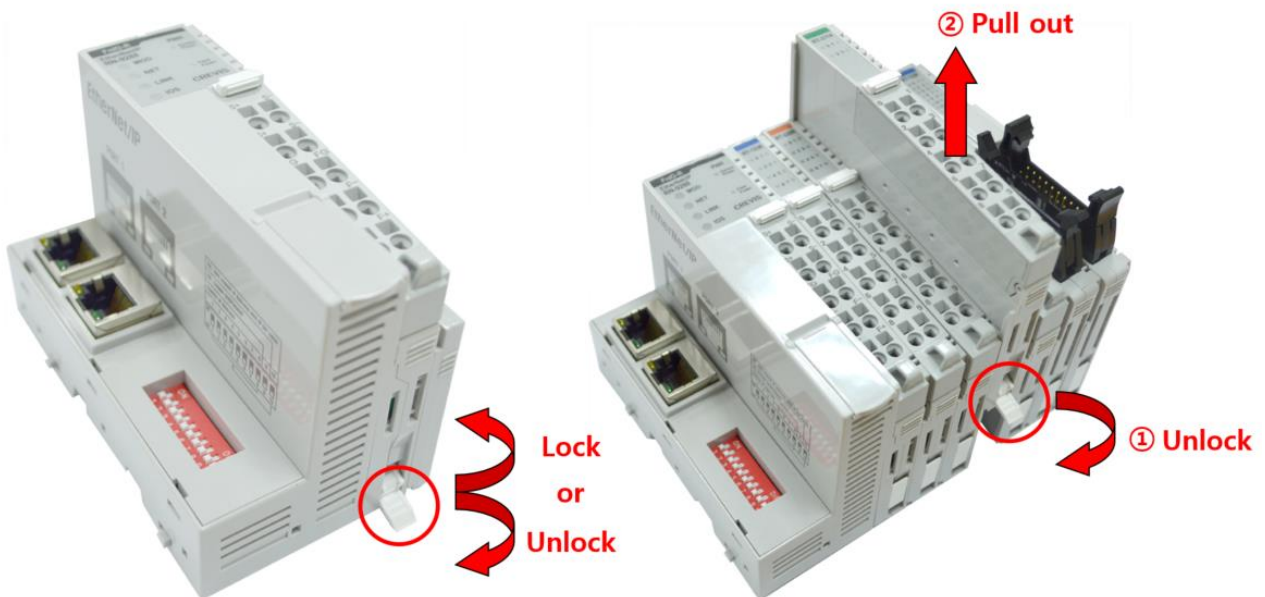

- As above figure in order to safeguard the G-Series module from jamming, it should be fixed onto the DIN rail with locking level. To do so, fold on the upper of the locking lever. To pull out the G-Series module, unfold the locking lever as below figure.

5.2. RTB (Removable Terminal Block)

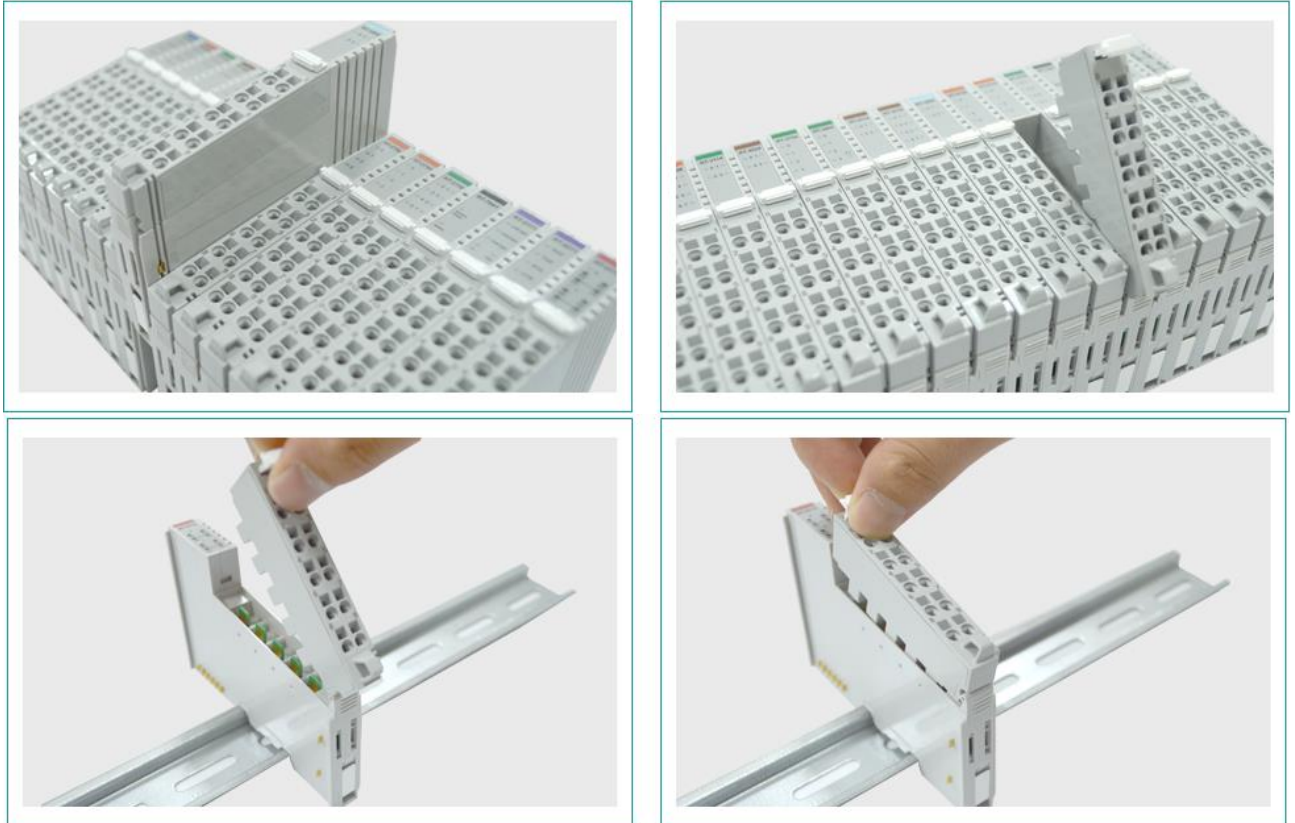

- " Whole terminal block can be combined and removed for the convenience.
- " There is a locking switch on the RTB for the easy combination and easy removal.
- " Easy combination and easy removal for IO modules on the din rail through One Touch Locking Switch.

6. G-Bus Pin Description

Communication between the GN series and the expansion module as well as system / field power supply of the bus modules is carried out via the internal bus. It is comprised of 6 data pin and 2 field power pin.

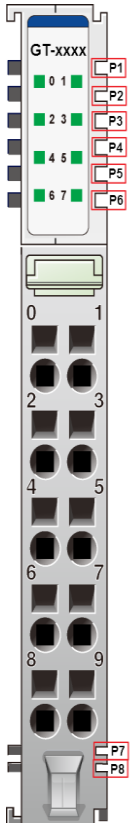

*Please refer to the table below regarding the pin description from P1 to P8.

No.	Description
P1	System Power (VCC)
P2	System Power (GND)
P3	GBUS TX +
P4	GBUS TX -
P5	GBUS RX +
P6	GBUS RX -
P7	Field Power (GND)
P8	Field Power (VCC)

DANGER



Do not touch data and field power pins in order to avoid soiling and damage by ESD noise.