



Main Features

- Onboard Intel® Atom™ processor E3826 Dual Core 1.46GHz
- 1 x DVI display output or 1x VGA converted from DVI-I
- 2 x Intel® I210-IT GbE LAN ports support WoL, teaming and PXE
- 1 x USB 2.0 & 1 x USB 3.0
- 2 x RS232/422/485 with 2.5KV isolation protection
- 1 x mini-PCIe socket for optional Wi-Fi/3.5G/4G LTE
- Front access CFast socket and RTC battery
- Support -20~70 °C extended operating temperature
- Typical 24V DC input with ±20% range

Product Overview

Powered by the latest generation of Intel® Atom™ processor E3826 (formerly codenamed "Bay Trail-I"), NIFE101 presents intelligent PC-based controller and Modbus RTU/TCP gateway for factory automation. NIFE101 support ACP ThinManager that offers management solutions for the modern factory by simplifying management and also support Indusoft for HMI and SCADA. Up to 4G DDR3L memory, NIFE101 have several options on storage devices like CFast and SSD. The NIFE 101 support extended operating temperature from -20 upto 70 degree C with typical DC input 24V ±20% range. The NIFE 101 has high integration ability with optional mini-PCIe module and 2 x COM ports with Isolation 2.5kv protect, which makes it a reliable connection with devices in IOT applications (with optional GbE LAN, Wi-Fi, 3.5G/4G LTE module). NIFE 101 is definitely the top choice for IOT/M2M intelligent system.

Specifications

CPU Support

- Onboard Intel® Atom™ processor E3826 Dual Core 1.46GHz
- Support Intel® Atom™ E3800 processor family from single core E3815, Dual Core E3825/E3826/E3827 and Quad Core E3845 with difference SKUs

Main Memory

- 1 x DDR3L SO-DIMM socket, support DDR3L 1066/1333 4GB RAM max., un-buffered and non-ECC

Display Option

- 1 x DVI display output
- 1 x VGA display output (converted from DVI-I to VGA adapter)

I/O Interface-Front

- ATX power on/off switch
- LEDs for power status, HDD access, battery Low, 2 x programming LEDs, 4x Tx/Rx LEDs
- 1 x External CFast socket
- 1 x SIM card holder
- 2 x Intel® I210-IT GbE LAN ports, support WoL, teaming and PXE
- 1 x DVI-I display output
- 1 x USB 3.0 (900mA per each)
- 1 x USB 2.0 (500mA per each)
- 2 x RS232/422/485 with 2.5KV isolation protection, support auto flow control

- Jumper-free setting on RS232/422/485
- Support RI function on COM2
- 1 x 2-pin remote power on/off switch
- 1 x 3-pic DC input, Typical 24V DC input with ±20% range

Storage Device

- 1 x CFast (SATA 2.0)
- 1 x 2.5" SSD (SATA 2.0)

Expansion Slot

- 1 x mini-PCIe socket for optional Wi-Fi/3.5G/4G LTE

Power Requirement

- Typical 24V DC input with ±20% range
- 1 x optional 24V, 60W power adapter

Dimensions

- 58mm (W) x 135.5mm (D) x 192.5mm (H)

Construction

- Aluminum and metal chassis with fanless design

Environment

- Operating temperature:
Ambient with air flow: -20°C to 70°C with industrial grade device (according to IEC60068-2-1, IEC60068-2-2, IEC60068-2-14)
- Storage temperature: -30°C to 85°C

Dimension Drawing

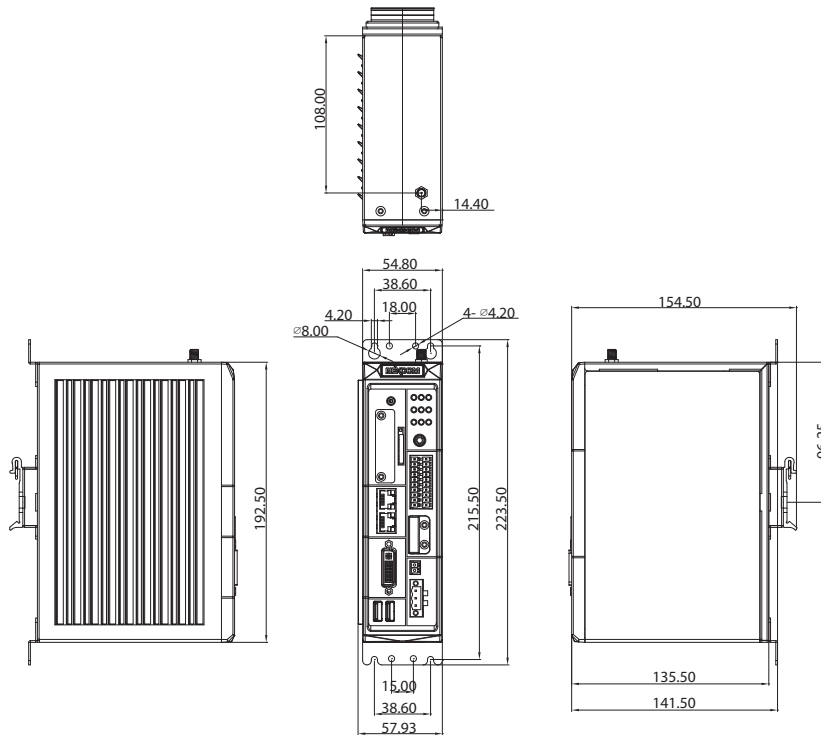

- Relative humidity: 10% to 95% (non-condensing)
- Shock protection:
 - SSD: 20G, half sine, 11ms, IEC60068-2-27
 - CFast: 50G, half sine, 11ms, IEC60068-2-27
- Vibration protection w/ CFast & SSD condition:
 - Random: 2Grms @ 5~500Hz, IEC60068-2-64
 - Sinusoidal: 2Grms @ 5~500Hz, IEC60068-2-6

Certifications

- CE
- FCC Class A

Support OS

- Windows 10 IoT Enterprise, 64-bit
- Windows 7, 32-bit/64-bit
- Windows Embedded Standard 7, 32-bit/64-bit
- Linux Kernel version 3.8.0
- Wind River® intelligent device platform XT 2.0

Ordering Information

- ♦ **NIFE 101 (P/N: 10J70010100X0)**
Intel® Atom™ processor E3826 Dual Core fanless system
- ♦ **24V, 60W AC/DC power adapter w/o power cord (P/N: 7400060033X00)**



IP SYSTEMES

8 rue du Colonel Chambonnet – BP67

69672 BRON Cedex

Tel. : 04 72 14 18 00

Fax : 04 72 14 18 01

www.ip-systemes.com – info@ip-systemes.fr