

Digital Input Module



GT-1xxx UserManual



Version 1.02

2020 CREVIS Co.,Ltd

DOCUMENT CHANGE SUMMARY				
REV	PAGE	REMARKS	DATE	EDITOR
1.00	New Document		18/07/30	Rachel
1.01	39 - 44	Added new products ' GT-1428'	20/06/17	Rachel
1.02	27	Wiring module connector	20/09/10	Rachel
	15, 20, 40	Channel status LED		

Table of Contents

1. Important Notes	6
1.1. Safety Instruction	7
1.1.1. Symbols	7
1.1.2. Safety Notes	7
1.1.3. Certification	7
2. Digital Input Module List	8
3. Specification	9
3.1. GT-1238	9
3.1.1. Wiring Diagram	9
3.1.2. LED Indicator	10
3.1.3. Channel Status LED	10
3.1.4. Environment Specification	11
3.1.5. Specification	12
3.1.6. Mapping Data into the Image Table	13
3.1.7. Parameter Data	13
3.2. GT-123F	14
3.2.1. Wiring Diagram	14
3.2.2. LED Indicator	15
3.2.3. Channel Status LED	15
3.2.4. Environment Specification	16
3.2.5. Specification	17
3.2.6. Mapping Data into the Image Table	18
3.2.7. Parameter Data	18
3.3. GT-12DF	19
3.3.1. Wiring Diagram	19
3.3.2. LED Indicator	20
3.3.3. Channel Status LED	20
3.3.4. Environment Specification	21
3.3.5. Specification	22
3.3.6. Mapping Data into the Image Table	23
3.3.7. Parameter Data	23

3.4. GT-12FA	24
3.4.1. Wiring Diagram	24
3.4.2. LED Indicator	25
3.4.3. Channel Status LED	25
3.4.4. Environment Specification	26
3.4.5. Specification	27
3.4.6. Mapping Data into the Image Table	28
3.4.7. Parameter Data	28
3.5. GT-1804	29
3.5.1. Wiring Diagram	29
3.5.2. LED Indicator	30
3.5.3. Channel Status LED	30
3.5.4. Environment Specification	31
3.5.5. Specification	32
3.5.6. Mapping Data into the Image Table	33
3.6. GT-1904	34
3.6.1. Wiring Diagram	34
3.6.2. LED Indicator	35
3.6.3. Channel Status LED	35
3.6.4. Environment Specification	36
3.6.5. Specification	37
3.6.6. Mapping Data into the Image Table	38
3.7. GT-1428	39
3.7.1. Wiring Diagram	39
3.7.2. LED Indicator	40
3.7.3. Channel Status LED	40
3.7.4. Environment Specification	41
3.7.5. Specification	42
3.7.6. Mapping Data into the Image Table	43
3.7.7. Parameter Data	44
4. Dimension	45
4.1. GT-1xx4(RTB), GT-1xx8(RTB)	45

4.2. GT-1xxF(Connector)	46
4.3. GT-1xxA	47
4.4. GT-12DF / 1428	48
5. Mounting	49
5.1. I/O Inserting and Removing Devices	49
5.2. RTB (Removable Terminal Block)	50
6. G-Bus Pin Description	51

1. Important Notes

Solid state equipment has operational characteristics differing from those of electromechanical equipment.

Safety Guidelines for the Application, Installation and Maintenance of Solid State Controls describes some important differences between solid state equipment and hard-wired electromechanical devices.

Because of this difference, and also because of the wide variety of uses for solid state equipment, all persons responsible for applying this equipment must satisfy themselves that each intended application of this equipment is acceptable.

In no event will CREVIS be responsible or liable for indirect or consequential damages resulting from the use or application of this equipment.

The examples and diagrams in this manual are included solely for illustrative purposes. Because of the many variables and requirements associated with any particular installation, CREVIS cannot assume responsibility or liability for actual use based on the examples and diagrams.

Warning!



- ✓ **If you don't follow the directions, it could cause a personal injury, damage to the equipment or explosion**
- Do not assemble the products and wire with power applied to the system. Else it may cause an electric arc, which can result into unexpected and potentially dangerous action by field devices. Arching is explosion risk in hazardous locations. Be sure that the area is non-hazardous or remove system power appropriately before assembling or wiring the modules.
- Do not touch any terminal blocks or IO modules when system is running. Else it may cause the unit to an electric shock or malfunction.
- Keep away from the strange metallic materials not related to the unit and wiring works should be controlled by the electric expert engineer. Else it may cause the unit to a fire, electric shock or malfunction

Caution!

- ✓ **If you disobey the instructions, there may be possibility of personal injury, damage to equipment or explosion. Please follow below Instructions.**
- " Check the rated voltage and terminal array before wiring. Avoid the circumstances over 50°C of temperature. Avoid placing it directly in the sunlight.
- " Avoid the place under circumstances over 85% of humidity.
- " Do not place Modules near by the inflammable material. Else it may cause a fire.
- " Do not permit any vibration approaching it directly.
- " Go through module specification carefully, ensure inputs, output connections are made with the specifications. Use standard cables for wiring.
- " Use Product under pollution degree 2 environment.

1.1. Safety Instruction

1.1.1. Symbols

<p>DANGER</p> 	<p>Identifies information about practices or circumstances that can cause an explosion in a hazardous environment, which may lead to personal injury or death property damage, or economic loss</p>
<p>IMPORTANT</p>	<p>Identifies information that is critical for successful application and understanding of the product</p>
<p>ATTENTION</p> 	<p>Identifies information about practices or circumstances that can lead to personal injury, property damage, or economic loss. Attentions help you to identity a hazard, avoid a hazard, and recognize the consequences</p>

1.1.2. Safety Notes

<p>DANGER</p> 	<p>The modules are equipped with electronic components that may be destroyed by electrostatic discharge. When handling the modules, ensure that the environment (persons, workplace and packing) is well grounded. Avoid touching conductive components, GBUS Pin.</p>
--	--

1.1.3. Certification

c-UL-us UL Listed Industrial Control Equipment, certified for U.S. and Canada

See UL File E235505

CE Certificate

EN 61000-6-2; Industrial Immunity

EN 61000-6-4; Industrial Emissions

Reach, RoHS (EU, CHINA)

2. Digital Input Module List

GT-Number	Description	ID	Production Status
GT-1238	Digital Input, 8Points, Universal(Sink or Source), 24VDC, 10RTB	1238	Active
GT-123F	Digital Input, 16 Points, Universal (Sink or Source), 24VDC, 20P Connector	123F	Active
GT-12DF	Digital Input, 16Points, Universal(Sink or Source), 24VDC, 18RTB	12DF	Active
GT-12FA	Digital Input, 32 Points, Universal (Sink or Source), 24VDC, 40P Connector	12FA	Active
GT-1804	Digital Input, 4 Points, AC Type, 120VAC, 10 RTB	1804	Active
GT-1904	Digital Input, 4 Points, AC Type, 220VAC, 10 RTB	1904	Active
GT-1428	8 Ch Sink Input / 8 ch Source Output with Diagnostic, 24Vdc	1428	Active

3. Specification

3.1.GT-1238

3.1.1. Wiring Diagram

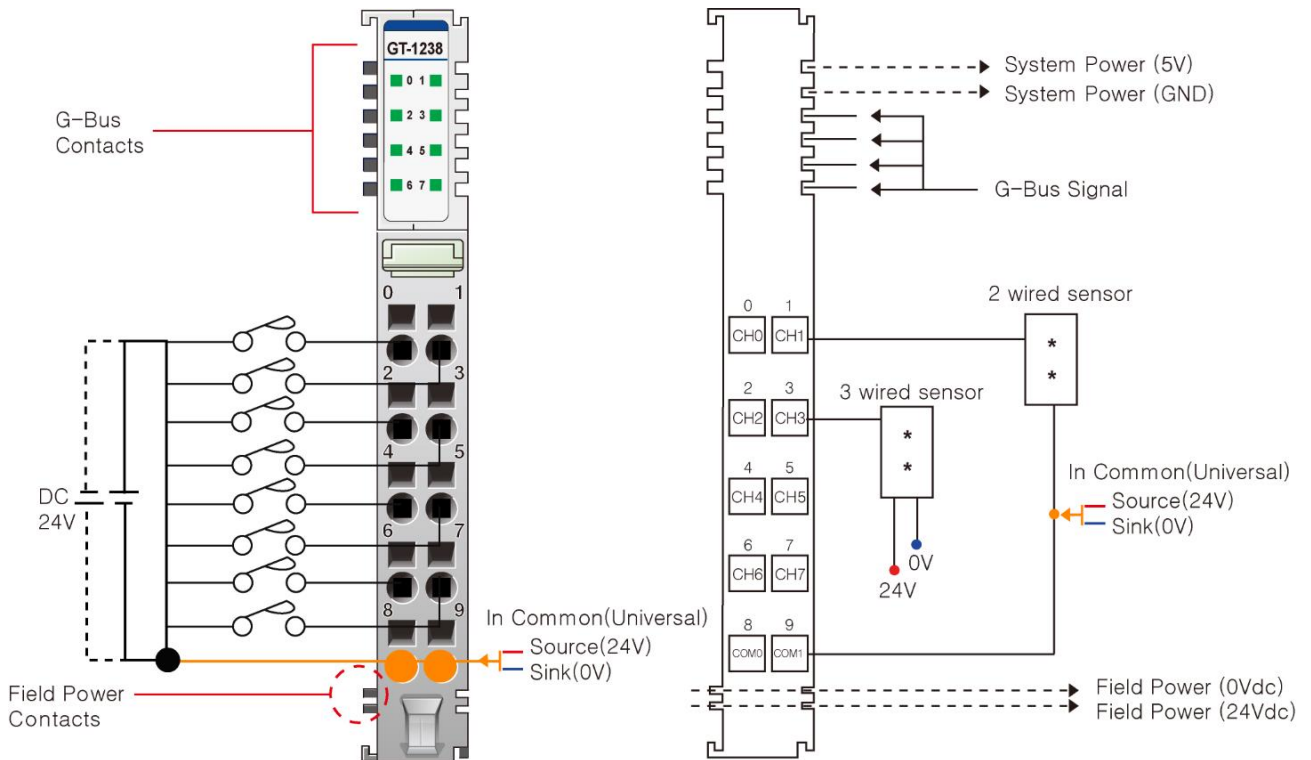

Pin No.	Signal Description	Signal Description	Pin No.
0	Input Channel 0	Input Channel 1	1
2	Input Channel 2	Input Channel 3	3
4	Input Channel 4	Input Channel 5	5
6	Input Channel 6	Input Channel 7	7
8	Common(Sink Oper : 0V / Source Oper : 24V)	Common(Sink Oper : 0V / Source Oper : 24V)	9

3.1.2. LED Indicator

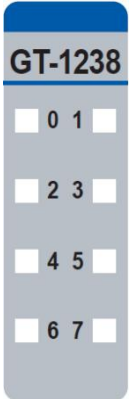

LED No.	LED Function / Description	LED Color
0	Input Channel 0	Green
1	Input Channel 1	Green
2	Input Channel 2	Green
3	Input Channel 3	Green
4	Input Channel 4	Green
5	Input Channel 5	Green
6	Input Channel 6	Green
7	Input Channel 7	Green

3.1.3. Channel Status LED

Status	LED	To indicate
Not signal	Off	No Input Signal
On Signal	Green	Input signal received

3.1.4. Environment Specification

Environmental Specification	
Operation Temperature	-40°C ~ 70°C
UL Temperature	-20°C ~ 60°C
Storage Temperature	-40°C ~ 85°C
Relative Humidity	5% ~ 90% Non-condensing
Mounting	DIN Rail
General Specification	
Shock Operating	IEC 60068-2-27
Vibration Resistance	Based on IEC 60068-2-6 DNVGL-CG-0039 : Vibration Class B, 4g
Industrial Emissions	EN61000-6-4/All : 2011
Industrial Immunity	EN61000-6-2 : 2005
Installation Position	Vertical and horizontal installation is available
Product Certifications	CE, UL, FCC

3.1.5. Specification

GT-1238	Specification
Input Specification	
Inputs Per Module	8 Points Universal Type
Indicators	8 Green Input Status
ON-state Voltage	24Vdc 15 ~ 26.4Vdc @ 70°C 15 ~ 28.8Vdc @ 60°C
ON-state Current	4mA @ 24Vdc 5mA @ 30Vdc
Off-state voltage	12.5Vdc @ 25°C
Input Signal Delay	OFF to ON : Max. 0.3ms ON to OFF : Max. 0.3ms
Input Filter	Adjustable, up to 10ms
Nominal Input Impedance	5.4K Ohm Typical
Common Type	8 Points / 2 Common(Universal)
General Specification	
Power Dissipation	Max. 35mA @ 5Vdc
Isolation	I/O to Logic : Photocoupler Isolation
UL field power	Supply voltage : 24Vdc nominal, Class2
Field Power	Supply Voltage : 24Vdc nominal Voltage Range : 15~30Vdc Power Dissipation : 0mA @ 24Vdc
Wiring	I/O Cable Max. 2.0mm ² (AWG 14)
Torque	0.8Nm(7lb-in)
Weight	59g
Module Size	12mm x 99mm x 70mm

3.1.6. Mapping Data into the Image Table.

" Input Module Data

D7	D6	D5	D4	D3	D2	D1	D0
----	----	----	----	----	----	----	----

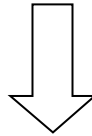

" Input Image Value

Bit No	Bit7	Bit6	Bit5	Bit4	Bit3	Bit2	Bit1	Bit0
Byte0	D7	D6	D5	D4	D3	D2	D1	D0

3.1.7. Parameter Data

" Valid Parameter length : 2 Bytes

" Parameter Data

Bit No	Bit7	Bit6	Bit5	Bit4	Bit3	Bit2	Bit1	Bit0
Byte 0	Input Filter Value : 0 ~ 10(unit : ms)							
Byte 1	Reserved							

3.2. GT-123F

3.2.1. Wiring Diagram

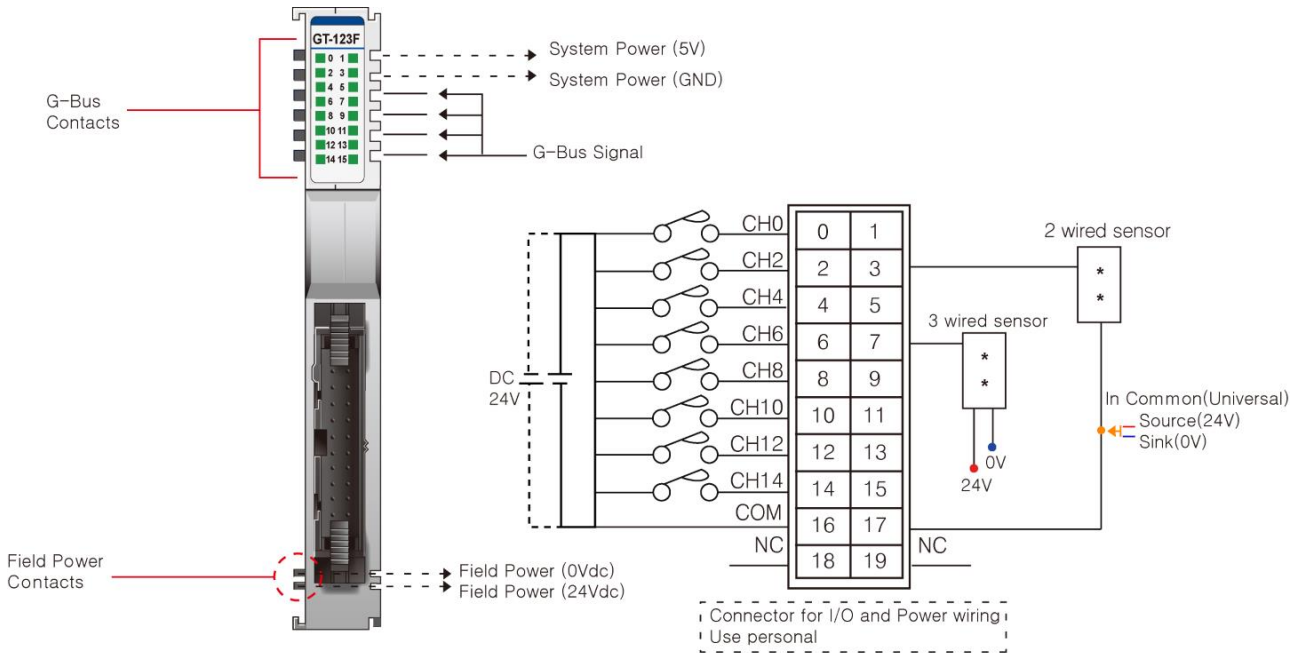

Pin No.	Signal Description	Signal Description	Pin No.
0	Input Channel 0	Input Channel 1	1
2	Input Channel 2	Input Channel 3	3
4	Input Channel 4	Input Channel 5	5
6	Input Channel 6	Input Channel 7	7
8	Input Channel 8	Input Channel 9	9
10	Input Channel 10	Input Channel 11	11
12	Input Channel 12	Input Channel 13	13
14	Input Channel 14	Input Channel 15	15
16	Common(Sink Oper.0V / Source Oper.24V)	Common(Sink Oper.0V / Source Oper.24V)	17
18	NC	NC	19

* Although the image above is GT-(Universal input module), it does not matter to refer to wiring diagram. Refer to the Sink (0V).

3.2.2. LED Indicator

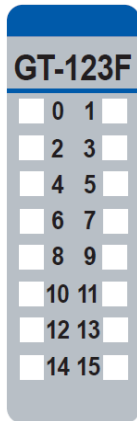

LED No.	LED Function / Description	LED Color
0	Input Channel 0	Green
1	Input Channel 1	Green
2	Input Channel 2	Green
3	Input Channel 3	Green
4	Input Channel 4	Green
5	Input Channel 5	Green
6	Input Channel 6	Green
8	Input Channel 8	Green
9	Input Channel 9	Green
10	Input Channel 10	Green
11	Input Channel 11	Green
12	Input Channel 12	Green
13	Input Channel 13	Green
14	Input Channel 14	Green
15	Input Channel 15	Green

3.2.3. Channel Status LED

Status	LED	To indicate
No Signal	Off	No Input Signal
On Signal	Green	Normal Operation

3.2.4. Environment Specification

Environmental Specification	
Operation Temperature	-40°C ~ 60°C
UL Temperature	-20°C ~ 60°C
Storage Temperature	-40°C ~ 85°C
Relative Humidity	5% ~ 90% Non-condensing
Mounting	DIN Rail
General Specification	
Shock Operating	IEC 60068-2-27
Vibration Resistance	Based on IEC 60068-2-6 DNVGL-CG-0039 : Vibration Class B, 4g
Industrial Emissions	EN61000-6-4/All : 2011
Industrial Immunity	EN 61000-6-2 : 2005
Installation Position	Vertical and horizontal installation is available
Product Certifications	CE, UL, FCC

3.2.5. Specification

GT-123F	Specification
Input Specification	
Inputs Per Module	16 Points Universal Type
Indicators	16 Green Input Status
ON-state Voltage	24Vdc nominal 15 ~ 30Vdc @ 60°C
ON-state Current	2.25mA @ 24Vdc 3mA @ 30Vdc
Off-state voltage	9.3Vdc @ 25°C
Input Signal Delay	OFF to ON : Max. 0.3ms ON to OFF : Max. 0.3ms
Input Filter	Adjustable, up to 10ms
Nominal Input Impedance	10.2K Ohm Typical
Common Type	16 Points / 2 Com
General Specification	
Power Dissipation	Max. 50mA @ 5Vdc
Isolation	I/O to Logic : Photocoupler Isolation
UL Field Power	Supply voltage : 24Vdc nominal, Class2
Field Power	Supply Voltage : 24Vdc nominal Voltage Range : 15~30Vdc Power Dissipation : 0mA @ 24Vdc
Wiring	Connector Type, up to AWG22 Module Connector : HIF3BA-20D-2.54DSA
Weight	52g
Module Size	12mm x 99mm x 70mm

3.2.6. Mapping Data into the Image Table

" Input Module Data

D7	D6	D5	D4	D3	D2	D1	D0
D15	D14	D13	D12	D11	D10	D9	D8

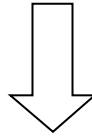

" Input Image Value

Bit No	Bit7	Bit6	Bit5	Bit4	Bit3	Bit2	Bit1	Bit0
Byte0	D7	D6	D5	D4	D3	D2	D1	D0
Byte1	D15	D14	D13	D12	D11	D10	D9	D8

3.2.7. Parameter Data

" Valid Parameter length : 2 Bytes

" Parameter Data

Bit No	Bit7	Bit6	Bit5	Bit4	Bit3	Bit2	Bit1	Bit0
Byte 0	Input Filter Value : 0 ~ 10(unit : ms)							
Byte 1	Reserved							

3.3 GT-12DF

3.3.1 Wiring Diagram

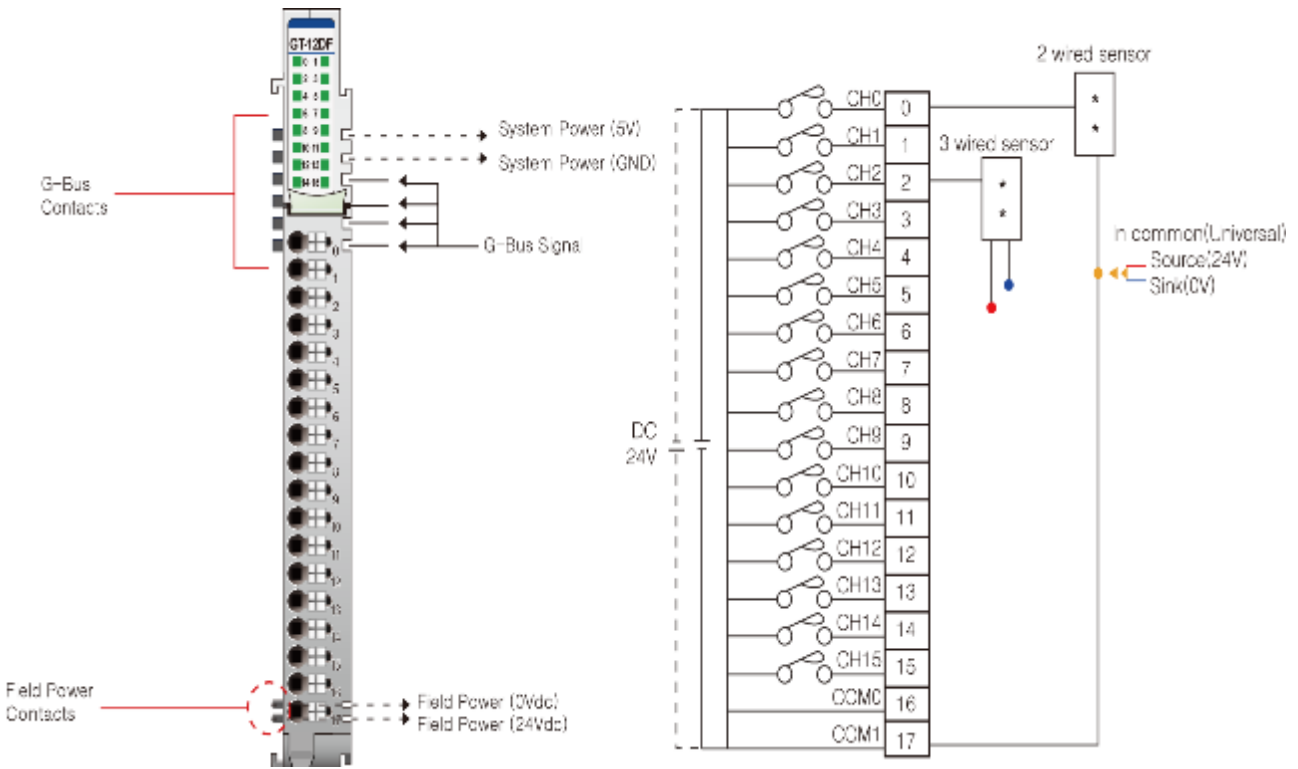

Pin No.	Signal Description	Signal Description	Pin No.
0	Input Channel 0	Input Channel 1	1
2	Input Channel 2	Input Channel 3	3
4	Input Channel 4	Input Channel 5	5
6	Input Channel 6	Input Channel 7	7
8	Input Channel 8	Input Channel 9	9
10	Input Channel 10	Input Channel 11	11
12	Input Channel 12	Input Channel 13	13
14	Input Channel 14	Input Channel 15	15
16	Common(Sink Oper.0V / Source Oper.24V)	Common(Sink Oper.0V / Source Oper.24V)	17

* Although the image above is GT-(Universal input module), it does not matter to refer to wiring diagram. Refer to the Sink (0V).

3.3.2 LED Indicator

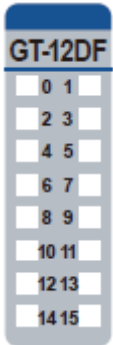

LEDNo.	LED Function / Description	LED Color
0	INPUT Channel 0	Green
1	INPUT Channel 1	Green
2	INPUT Channel 2	Green
3	INPUT Channel 3	Green
4	INPUT Channel 4	Green
5	INPUT Channel 5	Green
6	INPUT Channel 6	Green
7	INPUT Channel 7	Green
8	INPUT Channel 8	Green
9	INPUT Channel 9	Green
10	INPUT Channel 10	Green
11	INPUT Channel 11	Green
12	INPUT Channel 12	Green
13	INPUT Channel 13	Green
14	INPUT Channel 14	Green
15	INPUT Channel 15	Green

3.3.3 Channel Status LED

Status	LED	To indicate
Not Signal	Off	No Input signal
On Signal	Green	Normal Operation

3.3.4 Environment Specification

Environmental specification	
Operation Temperature	-40°C ~ 60°C
UL Temperature	-20°C ~ 60°C
Storage Temperature	-40°C ~ 85°C
Relative Humidity	5% ~ 90% Non-condensing
Mounting	DIN Rail
General specification	
Shock Operating	IEC 60068-2-27
Vibration Resistance	Based on IEC 60068-2-6 DNVGL-CG-0039 : Vibration Class B, 4g
Industrial Emissions	EN 61000-6-4 /All : 2011
Industrial Immunity	EN 61000-6-2 : 2005
Installation Position	Vertical and horizontal installation is available.
Product Certifications	CE, UL, FCC

3.3.5 Specification

GT-12DF	Specification
Input Specification	
Inputs per module	16 Points Universal Digital Type
Indicators	16 Green input state
ON-state Voltage	24V dc nominal 15 ~ 26.4Vdc @ 60°C
ON-state current	4mA @ 24Vdc 5mA @ 30Vdc
OFF-state voltage	12.5Vdc @ 25°C
Input Signal Delay	OFF to ON : 0.3ms Max ON to OFF : 0.3ms Max
Input filter	Adjustable, up to 10ms
Nominal Input Impedance	5.6K ohm typical
COMMON Type	16 points / 2 COM (Universal)
General specification	
Power dissipation	Max. 50mA @ 5.0Vdc
Isolation	I/O to Logic : Photocoupler isolation
UL field power	Supply voltage : 24Vdc nominal, Class 2
Field Power	Supply voltage : 24Vdc nominal Voltage range : 15~30Vdc Power dissipation: 0mA @ 24Vdc
Single Wiring	I/O Cable Max. 0.75mm ² (AWG 18)
Weight	63g
Module Size	12mm x 109mm x 70mm

3.3.6 Mapping Data into the Image Table

Input Module Data

D7	D6	D5	D4	D3	D2	D1	D0
D15	D14	D13	D12	D11	D10	D9	D8



Input Image Value

Bit No	Bit7	Bit6	Bit5	Bit4	Bit3	Bit2	Bit1	Bit0
Byte0	D7	D6	D5	D4	D3	D2	D1	D0
Byte1	D15	D14	D13	D12	D11	D10	D9	D8

3.3.7. Parameter Data

- Valid Parameter length: 2 Bytes
- Parameter Data

Bit No	Bit7	Bit6	Bit5	Bit4	Bit3	Bit2	Bit1	Bit0
Byte0	Input Filter value : 0 ~ 10 (unit : ms)							
Byte1	Reserved							

3.4. GT-12FA

3.4.1. Wiring Diagram

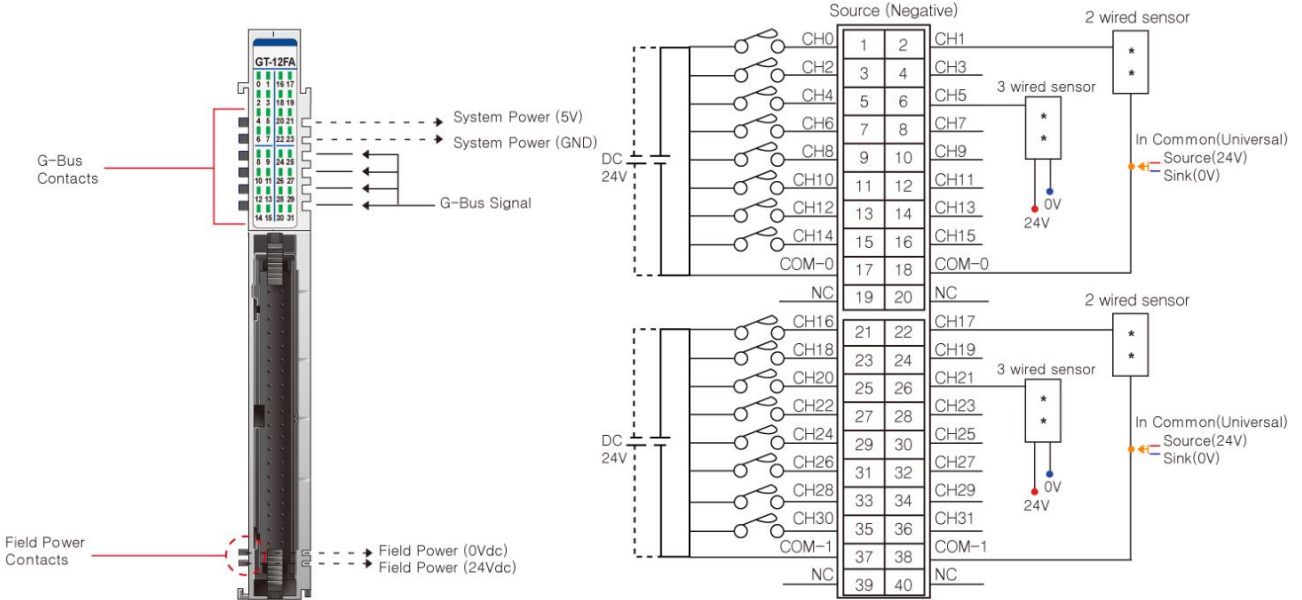

Pin No.	Signal Description	Signal Description	Pin No.
0	Input Channel 0	Input Channel 1	1
2	Input Channel 2	Input Channel 3	3
4	Input Channel 4	Input Channel 5	5
6	Input Channel 6	Input Channel 7	7
8	Input Channel 8	Input Channel 9	9
10	Input Channel 10	Input Channel 11	11
12	Input Channel 12	Input Channel 13	13
14	Input Channel 14	Input Channel 15	15
16	Common(Sink Oper.0V / Source Oper.24V)	Common(Sink Oper.0V / Source Oper.24V)	17
18	NC	NC	19
20	Input Channel 16	Input Channel 17	21
22	Input Channel 18	Input Channel 19	23
24	Input Channel 20	Input Channel 21	25
26	Input Channel 22	Input Channel 23	27
28	Input Channel 24	Input Channel 25	29

30	Input Channel 26	Input Channel 27	21
32	Input Channel 28	Input Channel 29	33
34	Input Channel 30	Input Channel 31	35
36	Common(Sink Oper.0V / Source Oper.24V)	Common(Sink Oper.0V / Source Oper.24V)	37
38	NC	NC	39

* Although the image above is GT-(Universal input module), it does not matter to refer to wiring diagram. Refer to the Sink (0V).

3.4.2. LED Indicator

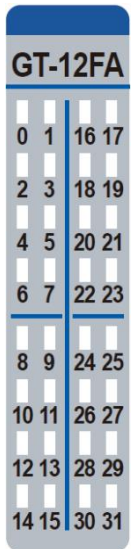

LED No.	LED Function / Description	LED Color
0	Input Channel 0	Green
1	Input Channel 1	Green
2	Input Channel 2	Green
...
31	Input Channel 31	Green

3.4.3. Channel Status LED

Status	LED	To indicate
Off Signal	Off	No Input Signal
On Signal	Green	Normal Operation

3.4.4. Environment Specification

Environmental specification	
Operating Temperature	-40°C~60°C
UL Temperature	-20°C~60°C
Storage Temperature	-40°C~85°C
Relative Humidity	5% ~ 90% non-condensing
Mounting	DIN rail
Shock Operating	IEC 60068-2-27
Vibration Resistance	Based on IEC 60068-2-6 DNVGL-CG-0039 : Vibration Class B, 4g
Industrial Emissions	EN61000-6-4/All : 2011
Industrial Immunity	EN61000-6-2 : 2005
Installation Position	Vertical and horizontal installation is available
Product Certifications	CE,UL, FCC

3.4.5. Specification

GT-12FA	Specification
Input Specification	
Inputs per module	32 Points Universal Type
Indicators	32 Green Input Status
ON-state Voltage	24Vdc nominal 15 ~ 30Vdc @ 60°C
ON-state Current	2.25mA @ 24Vdc 3mA @ 30Vdc
OFF-state Voltage	9.1V @ 25°C
Input Signal Delay	OFF to ON : Max. 0.2ms ON to OFF : Max. 0.2ms
Input filter	Adjustable, up to 10ms
Nominal Input Impedance	10.2K Ohm Typical
Common Type	32 Point / 4COM(Universal)
General Specification	
Power Dissipation	Max. 55mA @ 5Vdc
Isolation	I/O to Logic : Photocoupler Isolation
UL Field Power	Supply Voltage : 24 Vdc nominal, Class 2
Field Power	Supply Voltage : 24Vdc nominal Voltage Range : 15~30 Vdc Power dissipation : 0mA @ 24Vdc
Wiring	Connector Type, up to AWG22 Module connector : HIF3BA-40D-2.54DSA
Weight	59g
Module Size	12mm x 109mm x 70mm

3.4.6. Mapping Data into the Image Table

" Input Module Data

D7	D6	D5	D4	D3	D2	D1	D0
D15	D14	D13	D12	D11	D10	D9	D8
D23	D22	D21	D20	D19	D18	D17	D16
D31	D30	D29	D28	D27	D26	D25	D24

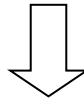

" Input Image Value

Bit No	Bit7	Bit6	Bit5	Bit4	Bit3	Bit2	Bit1	Bit0
Byte0	D7	D6	D5	D4	D3	D2	D1	D0
Byte1	D15	D14	D13	D12	D11	D10	D9	D8
Byte2	D23	D22	D21	D20	D19	D18	D17	D16
Byte3	D31	D30	D29	D28	D27	D26	D25	D24

3.4.7. Parameter Data

" Valid Parameter length : 2 Bytes

" Parameter Data

Bit No	Bit7	Bit6	Bit5	Bit4	Bit3	Bit2	Bit1	Bit0
Byte 0	Input Filter Value : 0 ~ 10(unit : ms)							
Byte 1	Reserved							

3.5. GT-1804

3.5.1. Wiring Diagram

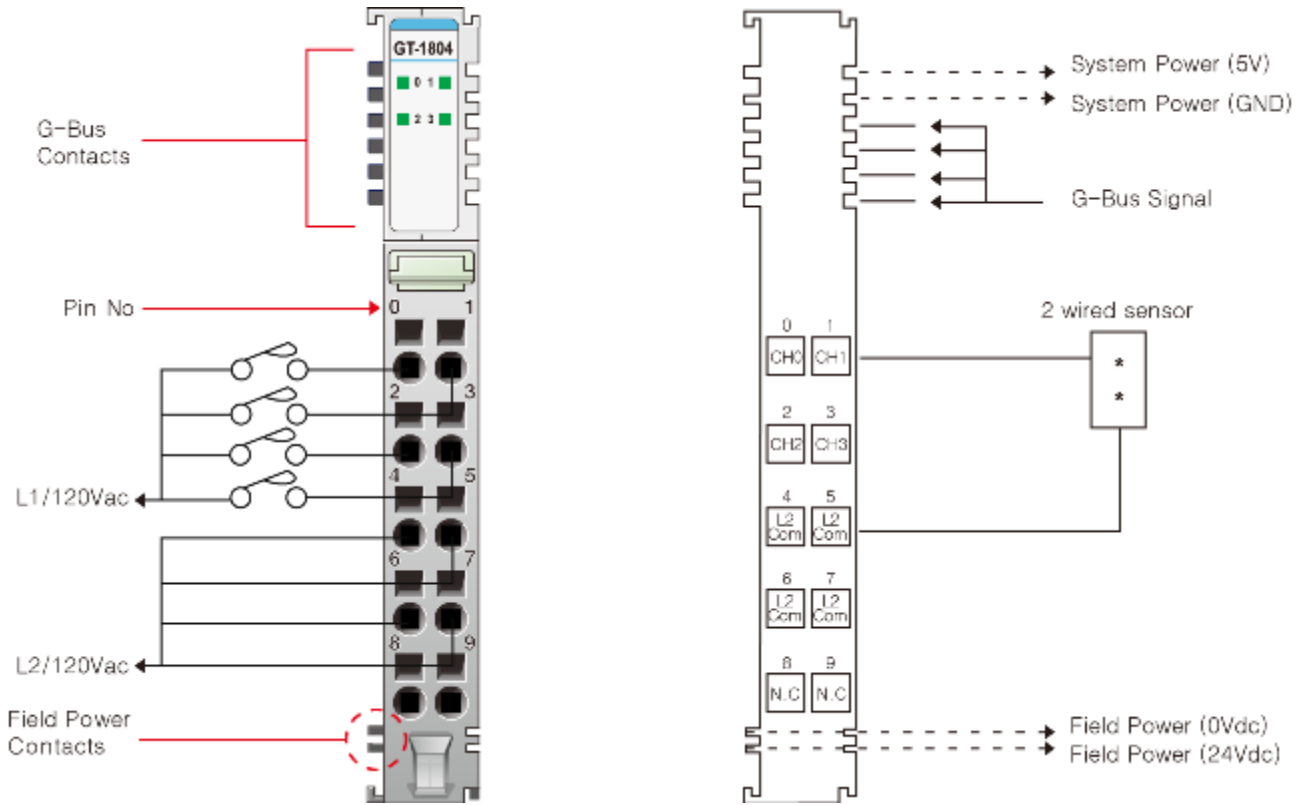

Pin No.	Signal Description	Signal Description	Pin No.
0	Input Channel 0	Input Channel 1	1
2	Input Channel 2	Input Channel 3	3
4	Input Channel Common (L2/N)	Input Channel Common (L2/N)	5
6	Input Channel Common (L2/N)	Input Channel Common (L2/N)	7
8	N.C	N.C	9

3.5.2. LED Indicator

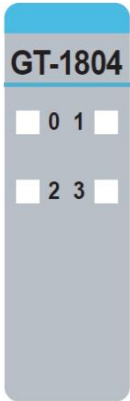

LED No.	LED Function / Description	LED Color
0	Input Channel 0	Green
1	Input Channel 1	Green
2	Input Channel 2	Green
3	Input Channel 3	Green

3.5.3. Channel Status LED

Status	LED	To indicate
Off Signal	Off	No Input Signal
On Signal	Green	Normal Operation

3.5.4. Environment Specification

Environmental specification	
Operating Temperature	-40°C~60°C
UL Temperature	-20°C~60°C
Storage Temperature	-40°C~85°C
Relative Humidity	5% ~ 90% non-condensing
Mounting	DIN rail
General specification	
Shock Operating	IEC 60068-2-27
Vibration Resistance	Based on IEC 60068-2-6 DNVGL-CG-0039 : Vibration Class B, 4g
Industrial Emissions	EN61000-6-4/All : 2011
Industrial Immunity	EN61000-6-2 : 2005
Installation Position	Vertical and horizontal installation is available.
Product Certifications	CE, UL, FCC

3.5.5. Specification

GT-1804	Specification
Input Specification	
Inputs Per Module	4 Points
Indicators	4 Green input state
ON-state Voltage	120Vac nominal 85 ~ 132Vac @ 60°C
ON-state Current	7.5mA @120Vac
OFF-state Voltage	45Vac@ 25°C
Input Signal Delay	OFF to ON : 30mS ON to OFF : 130mS
Nominal Input Impedance	17.5KΩ typical
Frequency Range	60Hz
Common Type	4 Points / 4 Common (L2/N)
General Specification	
Power Dissipation	Max. 30mA @ 5.0Vdc
Isolation	I/O to Logic : Photocoupler isolation
UL field power	Supply voltage : 24Vdc nominal, Class 2
Field Power	Field Power passes through to the next module. Supply voltage : 24Vdc Voltage range : 15V ~ 30Vdc (AC Power Not used)
Wiring	I/O Cable Max. 2.0mm ² (AWG 14)
Weight	57g
Module Size	12mm x 99mm x 70mm

3.5.6. Mapping Data into the Image Table

" Input Module Data

D3	D2	D1	D0
----	----	----	----

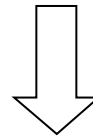

" Input Image Value

Bit No	Bit7	Bit6	Bit5	Bit4	Bit3	Bit2	Bit1	Bit0
Byte0	Reserved				D3	D2	D1	D0

3.6. GT-1904

3.6.1. Wiring Diagram

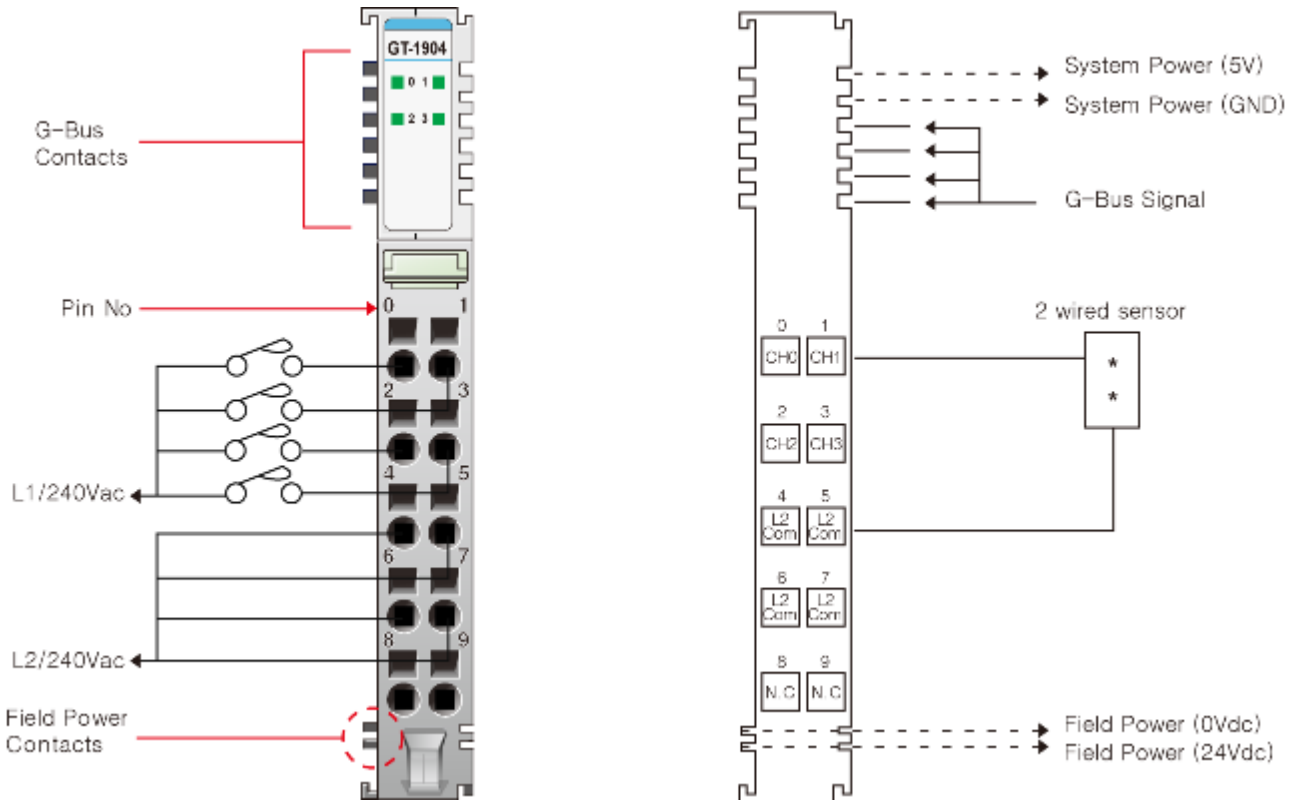

Pin No.	Signal Description	Signal Description	Pin No.
0	Input Channel 0	Input Channel 1	1
2	Input Channel 2	Input Channel 3	3
4	Input Channel Common (L2/N)	Input Channel Common (L2/N)	5
6	Input Channel Common (L2/N)	Input Channel Common (L2/N)	7
8	N.C	N.C	9

3.6.2. LED Indicator

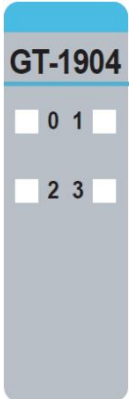

LED No.	LED Function / Description	LED Color
0	Input Channel 0	Green
1	Input Channel 1	Green
2	Input Channel 2	Green
3	Input Channel 3	Green

3.6.3. Channel Status LED

Status	LED	To indicate
Off Signal	Off	No Input Signal
On Signal	Green	Normal Operation

3.6.4. Environment Specification

Environmental specification	
Operating Temperature	-40°C~60°C
UL Temperature	-20°C~60°C
Storage Temperature	-40°C~85°C
Relative Humidity	5% ~ 90% non-condensing
Mounting	DIN rail
General specification	
Shock Operating	IEC 60068-2-27
Vibration Resistance	Based on IEC 60068-2-6 DNVGL-CG-0039 : Vibration Class B, 4g
Industrial Emissions	EN 61000-6-4/All : 2011
Industrial Immunity	EN 61000-6-2 : 2005
Installation Position	Vertical and horizontal installation is available.
Product Certifications	CE, UL, FCC

3.6.5. Specification

GT-1904	Specification
Input Specification	
Inputs Per Module	4 Points
Indicators	4 Green input state
ON-state Voltage	240Vac nominal 170Vac ~ 264Vac @ 60°C
ON-state Current	10mA @ 240Vac
OFF-state Voltage	115Vac @ 25°C
Input Signal Delay	OFF to ON : 30mS Max ON to OFF : 140mS Max
Nominal Input Impedance	26.5 KΩ Typical
Frequency Range	60Hz
Common Type	4 Points / 4 Common (L2/N)
General Specification	
Power Dissipation	Max. 30mA @ 5Vdc
Isolation	I/O to Logic : Photocoupler Isolation
UL field power	Supply voltage : 24Vdc nominal, Class 2
Field Power	Field Power passes through to the next module. Supply Voltage : 24Vdc Voltage Range : 15 ~ 30Vdc (AC Power Not Used)
Wiring	I/O Cable Max. 2.0mm ² (AWG 14)
Torque	0.8Nm(7lb-in)
Weight	57g
Module Size	12mm x 99mm x 70mm

3.6.6. Mapping Data into the Image Table

" Input Module Data

D3	D2	D1	D0
----	----	----	----

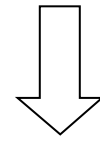

" Input Image Value

Bit No	Bit7	Bit6	Bit5	Bit4	Bit3	Bit2	Bit1	Bit0
Byte0	Reserved				D3	D2	D1	D0

3.7. GT-1428

3.7.1. Wiring Diagram

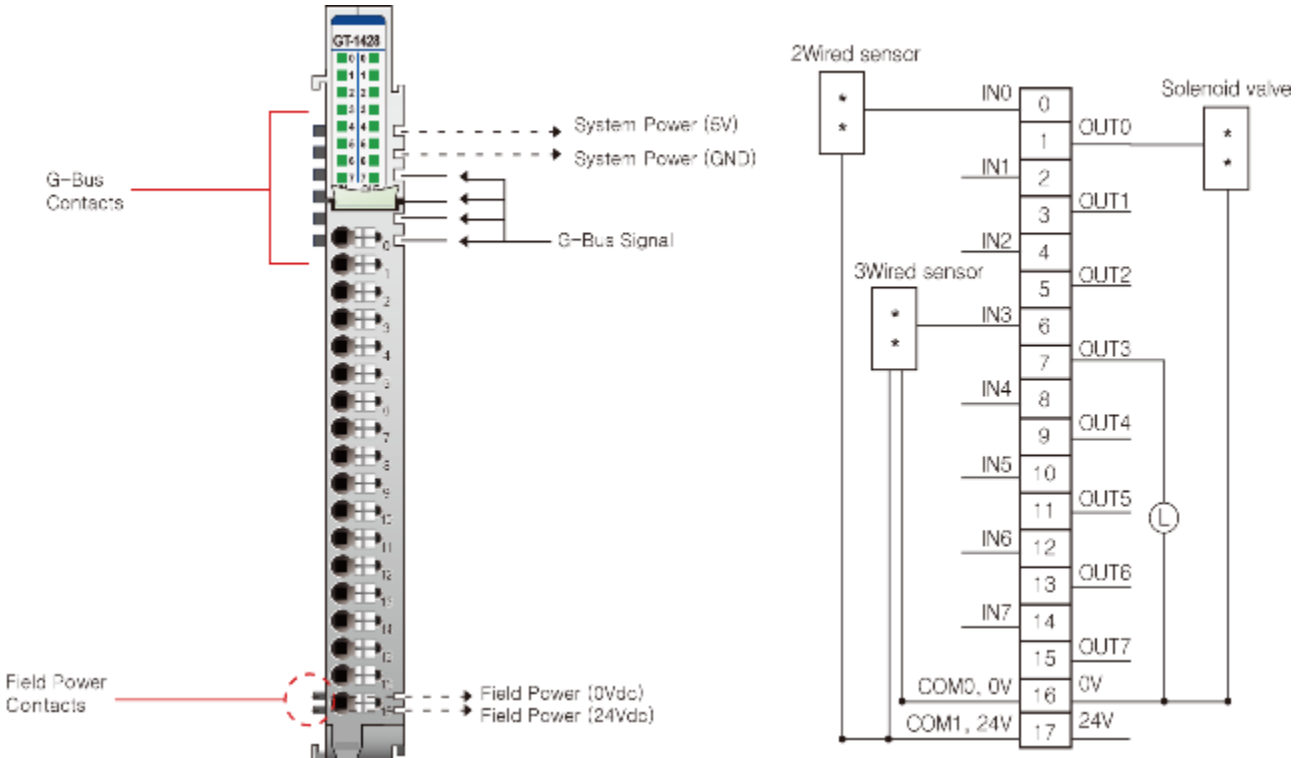

Pin No.	Signal Description	Pin No.	Signal Description
0	Input Channel 0	9	Output channel 4
1	Output channel 0	10	Input Channel 5
2	Input Channel 1	11	Output channel 5
3	Output channel 1	12	Input Channel 6
4	Input Channel 2	13	Output channel 6
5	Output channel 3	14	Input Channel 7
6	Input Channel 3	15	Output channel 7
7	Output channel 3	16	Common (Field Power 0V)
8	Input Channel 4	17	Common (Field Power 24V)

3.7.2. LED Indicator

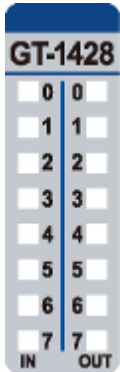

LED No.	LED Function / Description	LED Color
0(Left side)	INPUT Channel 0	Green
1	INPUT Channel 1	Green
2	INPUT Channel 2	Green
3	INPUT Channel 3	Green
4	INPUT Channel 4	Green
5	INPUT Channel 5	Green
6	INPUT Channel 6	Green
7	INPUT Channel 7	Green
0(Right side)	OUTPUT Channel 0	Green
1	OUTPUT Channel 1	Green
2	OUTPUT Channel 2	Green
3	OUTPUT Channel 3	Green
4	OUTPUT Channel 4	Green
5	OUTPUT Channel 5	Green
6	OUTPUT Channel 6	Green
7	OUTPUT Channel 7	Green

3.7.3. Channel Status LED

- LED No. 0~7(Left side)

Status	LED	To indicate
Not Signal	Off	No Input Signal
On Signal	Green	Normal Operation

- LED No. 0~7(Right side)

Status	LED	To indicate
Not Signal	Off	No Input Signal
On Signal	Green	Normal Operation
Channel Fault	Flash	Short to GND
		Short to VCC(Off State)
		Overcurrent
		Overtemperature

3.7.4. Environment Specification

Environmental specification	
Operating Temperature	-40°C~60°C
UL Temperature	-20°C~60°C
Storage Temperature	-40°C~85°C
Relative Humidity	5% ~ 90% non-condensing
Mounting	DIN rail
General specification	
Shock Operating	IEC 60068-2-27
Vibration Resistance	Based on IEC 60068-2-6 DNVGL-CG-0039 : Vibration Class B, 4g
Industrial Emissions	EN 61000-6-4/All : 2011
Industrial Immunity	EN 61000-6-2 : 2005
Installation Position	Vertical and horizontal installation is available.
Product Certifications	CE, UL, FCC

3.7.5. Specification

GT-1428	Specification
Input Specification	
Inputs Per Module	8 Points Sink type
Indicators	8 Green input state
ON-state Voltage	240Vac nominal 15 ~ 30Vdc @ 60°C
OFF-state Voltage	8Vdc @ 25 °C
ON-state Current	2.25mA @ 24Vdc 3 mA @ 30Vdc
Input signal delay	OFF to ON : 0.3 ms Max ON to OFF : 0.3 ms Max
Input filter	Adjustable, up to 10ms
Nominal Input Impedance	10.2 KΩ Typical
Output Specification	
Output per module	8 Points Source type
Indicators	8 Green output state
Output Voltage Range	24Vdc Nominal 15Vdc ~ 30 Vdc @ 60°C
ON-state voltage drop	0.3Vdc @ 25°C 0.6Vdc @ 60°C
ON-State Min. Current	Min 1 mA
OFF-State Leakage current	Max. 10uA
Output Signal Delay	OFF to ON : 0.1ms maximum ON to OFF : 0.35ms maximum
Output Current Rating	Max. 0.5A per channel / Max. 4A per unit
Protection	Over Current limit : 2.2A@ 25°C per each channels Thermal Shutdown : 175°C Short circuit protection
General Specification	
Power Dissipation	Max. 55mA @ 5.0Vdc
Isolation	I/O to Logic : Photocoupler Isolation
UL field power	Supply voltage : 24Vdc nominal, Class 2
Field Power	Supply Voltage : 24Vdc nominal Voltage Range : 15 ~ 30Vdc Power dissipation : 40mA @ 24Vdc
Wiring	I/O Cable Max. 0.75mm ² (AWG 18)
Weight	63g
Module Size	12mm x 109mm x 70mm

3.7.6. Mapping Data into the Image Table

" Input Module Data

D7	D6	D5	D4	D3	D2	D1	D0
D15	D14	D13	D12	D11	D10	D9	D8

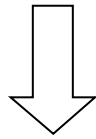

" Input Image Value

Bit No	Bit7	Bit6	Bit5	Bit4	Bit3	Bit2	Bit1	Bit0
Byte0	D7	D6	D5	D4	D3	D2	D1	D0
Byte1	D15	D14	D13	D12	D11	D10	D9	D8

" Output Image Value

Bit No	Bit7	Bit6	Bit5	Bit4	Bit3	Bit2	Bit1	Bit0
Byte0	D7	D6	D5	D4	D3	D2	D1	D0

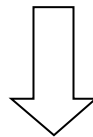

" Output Module Data

D7	D6	D5	D4	D3	D2	D1	D0
----	----	----	----	----	----	----	----

3.7.7. Parameter Data

Valid Parameter Length : 4 Bytes

Parameter Data

Bit No.	Bit7	Bit6	Bit5	Bit4	Bit3	Bit2	Bit1	Bit0
Byte0	Fault Action (ch0~ch7) 0: Fault value, 1:Hold last state							
Byte1	Fault value (ch0~ch7) 0:Off, 1:On							
Byte2	Input Filter value : 0 ~ 10 (unit : ms)							
Byte3	Reserved							

4. Dimension

4.1. GT-1xx4(RTB), GT-1xx8(RTB)

(
m
)

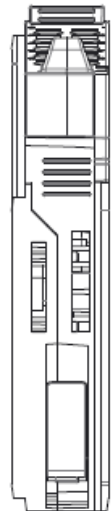
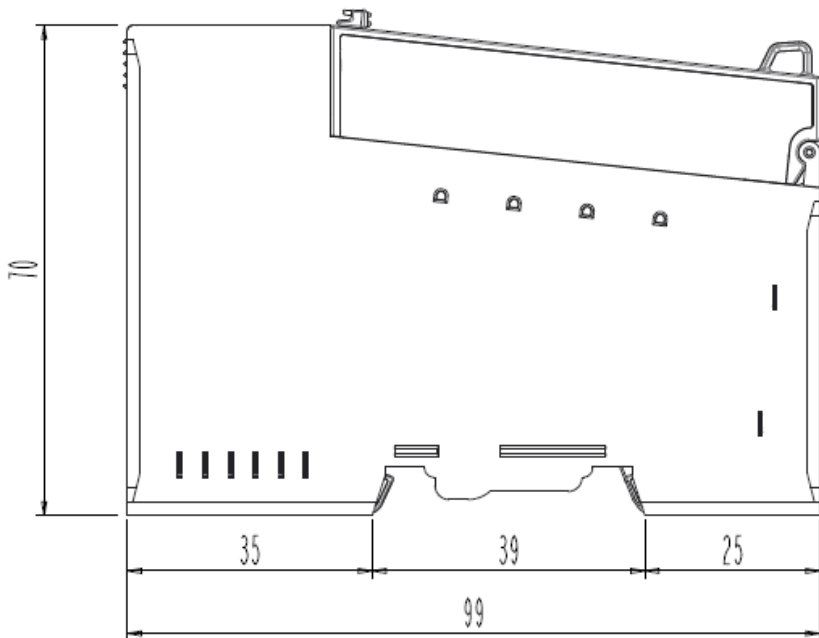
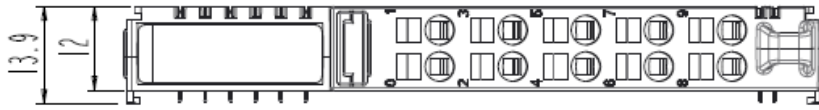

4.2. GT-1xxF(20P Connector)

(mm)

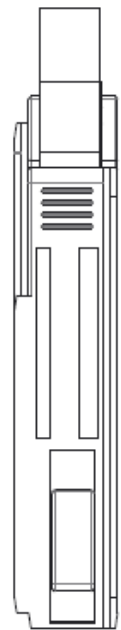
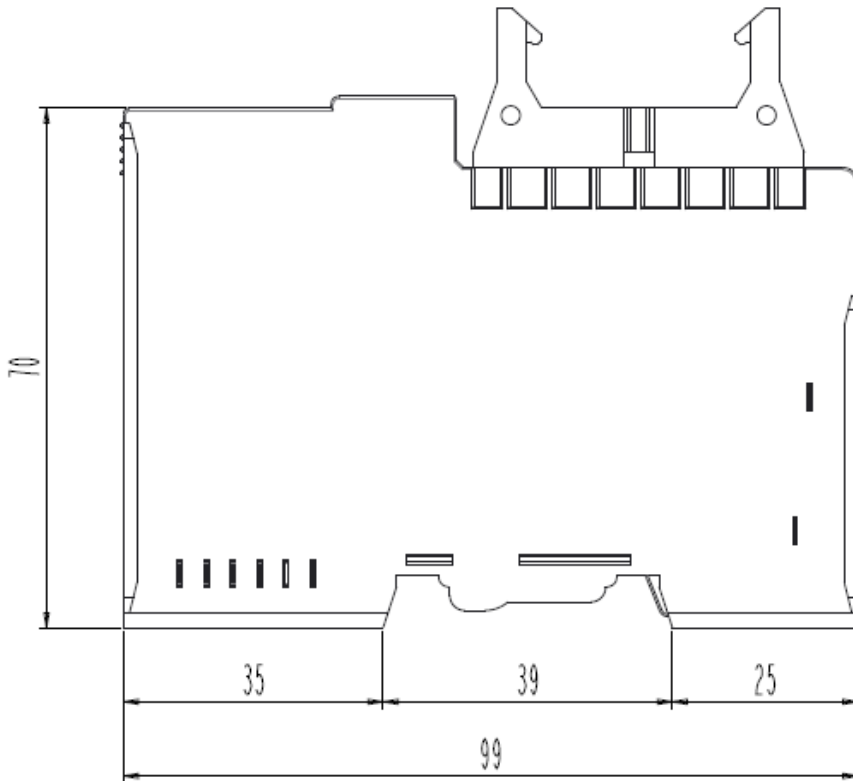

4.3. GT-1xxA (40P Connector)

(mm)

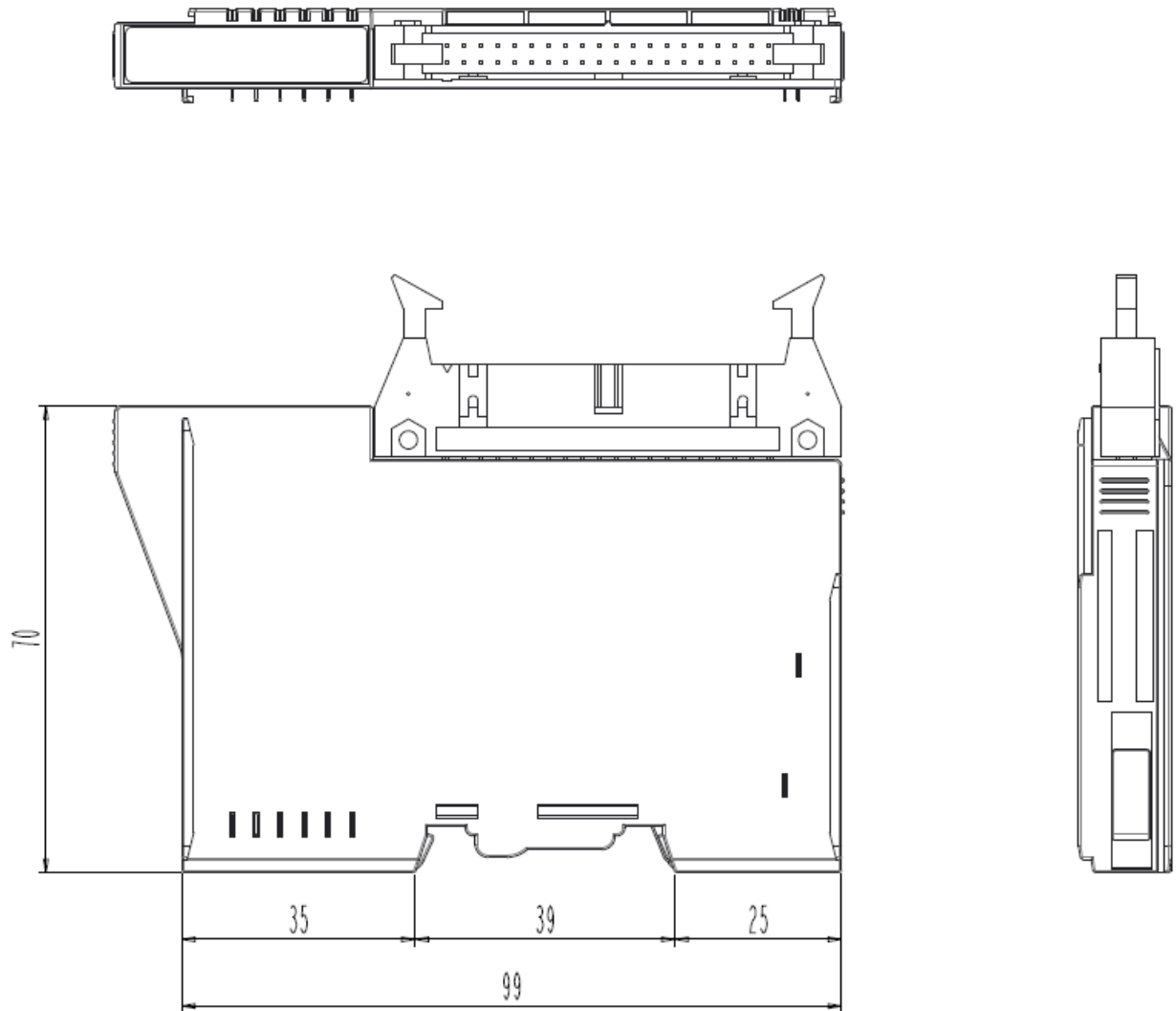

4.4. GT-12DF, 1428 (18 RTB)

(mm)

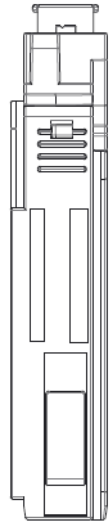
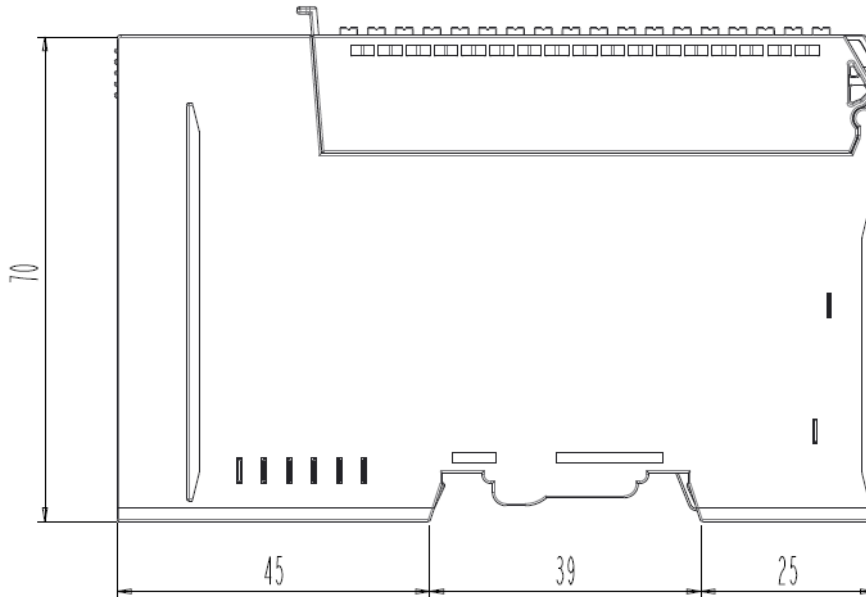
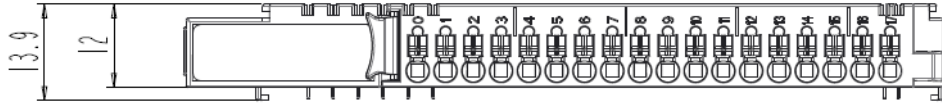

5. Mounting

Caution!

" Hot surface!

The surface of the housing can become hot during operation. If the device was operated at high ambient temperatures, allow it to be cool before touching it.

Notice!

" Perform work on devices only if they are de-energized!

Working on energized devices can damage them. Therefore, turn off the power supply before working on the devices.

5.1. I/O Inserting and Removing Devices

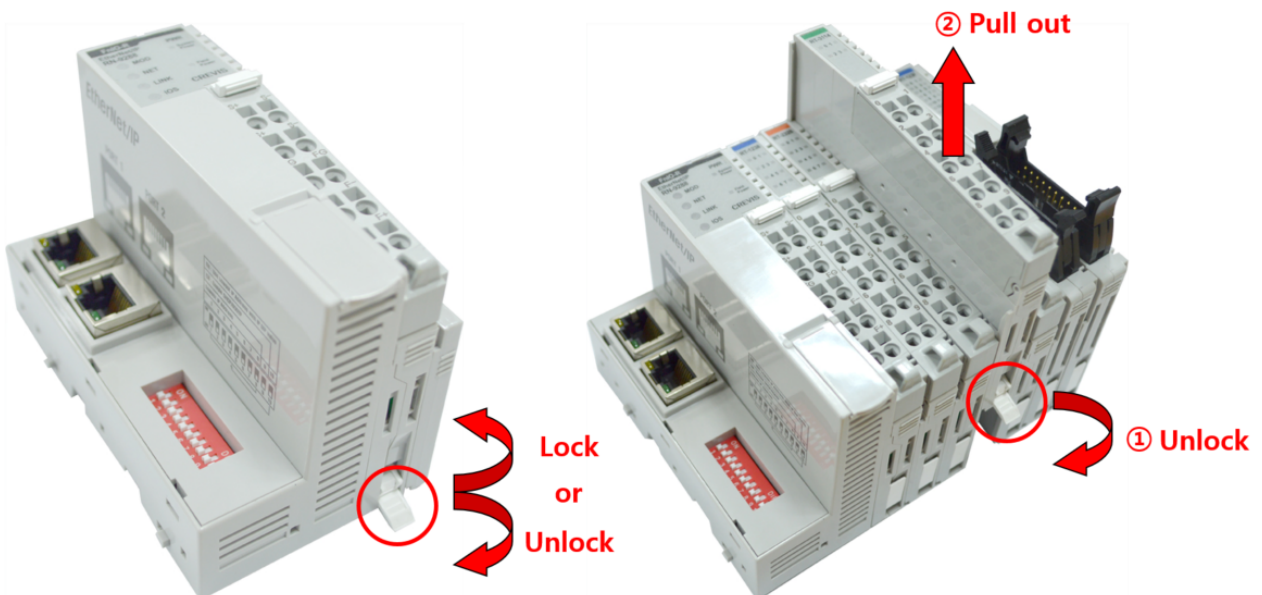

- As above figure in order to safeguard the G-Series module from jamming, it should be fixed onto the DIN rail with locking level. To do so, fold on the upper of the locking lever.

To pull out the G-Series module, unfold the locking lever as below figure.

5.2. RTB (Removable Terminal Block)

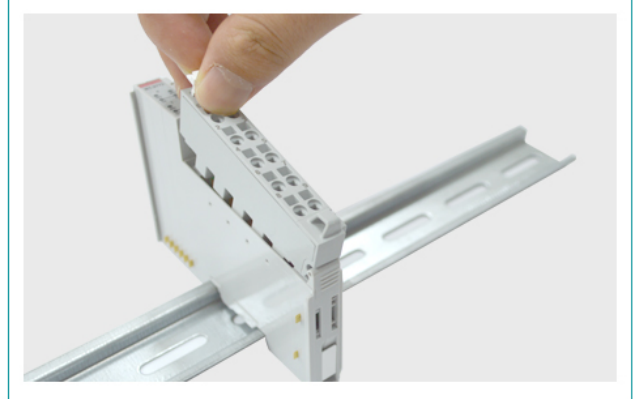
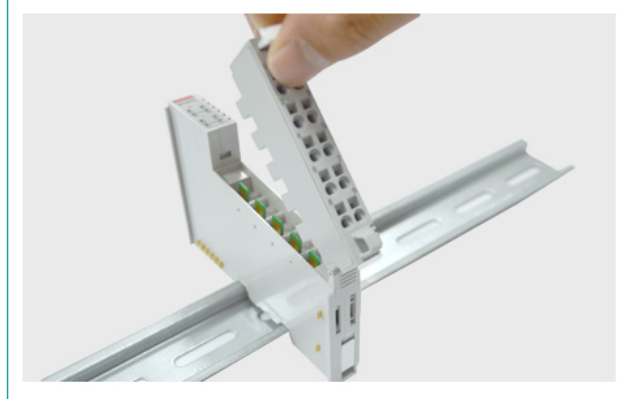
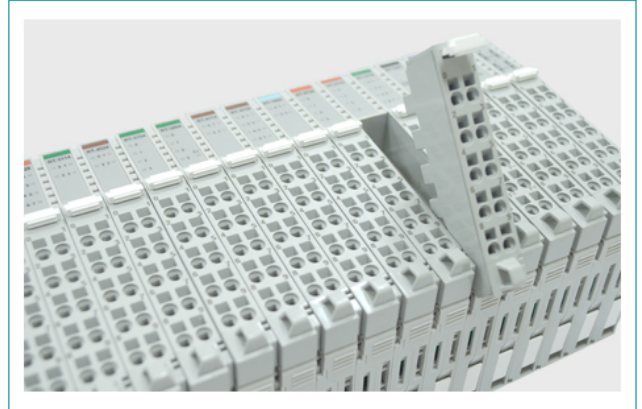
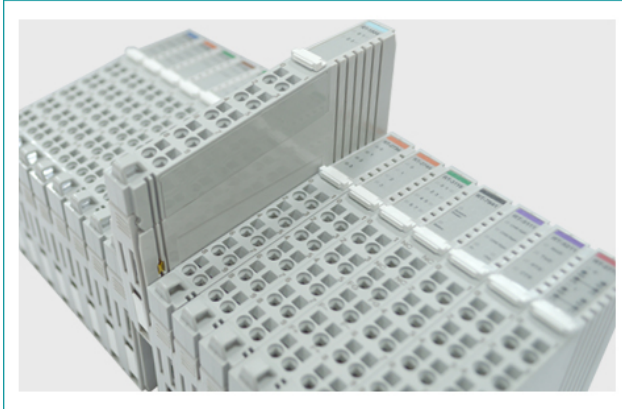

- " Whole terminal block can be combined and removed for the convenience.
- " There is a locking switch on the RTB for the easy combination and easy removal.
- " Easy combination and easy removal for I/O modules on the din rail through One Touch Locking Switch.

6. G-Bus Pin Description

Communication between the GN series and the expansion module as well as system / field power supply of the bus modules is carried out via the internal bus. It is comprised of 6 data pin and 2 field power pin.

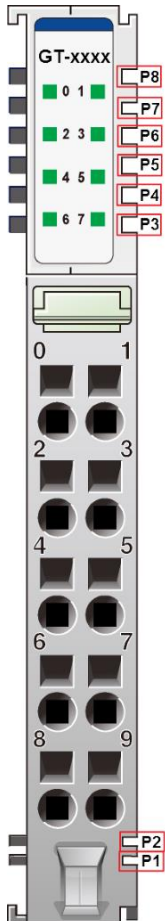

*Please refer to the table below regarding the pin description from P1 to P8.

No.	Description
P1	Field Power (VCC)
P2	Field Power (GND)
P3	G-BUS CLK
P4	G-BUS MISO
P5	G-BUS MOSI
P6	G-BUS Token
P7	System Power (GND)
P8	System Power (VCC)

DANGER



Do not touch data and field power pins in order to avoid soiling and damage by ESD noise.

APPENDIX A

A.1 Product List

No.	GT-Number	Description	ID(hex)
Digital Input Module			
1	GT-1238	8 Points, Universal, 24Vdc, 10RTB	1238
2	GT-123F	16 Points, Universal, 24Vdc, 20P connector	123F
3	GT-12DF	16 Points, Universal, 24Vdc, 18RTB	12DF
4	GT-12FA	32 Points, Universal, 24Vdc, 40P connector	12FA
5	GT-1428	8 Sink Input / 8 Source Output with Diagnostic, 24Vdc	1428
6	GT-1804	4 Points, 120Vac, 10RTB	1804
7	GT-1904	4 Points, 240Vac, 10RTB	1904
Digital Output Module			
8	GT-2318	8 Points, Sink, 24Vdc/0.5A, 10RTB	2318
9	GT-2328	8 Points, Source, 24Vdc/0.5A, 10RTB	2328
10	GT-221F	16 Points, Sink, 24Vdc/0.3A, 20P connector	221F
11	GT-222F	16 Points, Source, 24Vdc/0.3A, 20P connector	222F
12	GT-225F	16 Points, Sink, 24Vdc/0.3A, 18RTB	225F
13	GT-226F	16 Points, Source, 24Vdc/0.3A, 18RTB	226F
14	GT-22BA	32 Points, Sink, 24Vdc/0.3A, 40P connector	22BA
15	GT-22CA	32 Points, Source, 24Vdc/0.3A, 40P connector	22CA
16	GT-2418	8 Channels Sink Output with Diagnostics	2418
17	GT-2428	8 Channels Source Output with Diagnostics	2428
18	GT-2618	8 Points, Sink, 24Vdc/2A, 10RTB	2618
19	GT-2628	8 Points, Source, 24Vdc/2A, 10RTB	2628
20	GT-2734	4 Points, MOS Relay, 240Vdc/ac, 0.5A, 10RTB	2734
21	GT-2738	8 Points, MOS Relay Output Terminal, 240Vdc, 0.5A	2738
22	GT-2744	4 Points, Relay, 24Vdc/2A, 240Vac/2A, 10RTB	2744
23	GT-2764	4 Points, MOS Relay, 24Vdc/ac, 2A, 10RTB	2764
24	GT-2768	8 Points, Relay Output Terminal, 24Vdc/ac, 2A	2768
25	GT-2784	4 Points, MOS Relay, 110Vdc/ac, 1A, 10RTB	2784
26	GT-2788	8 Points, Relay Output Terminal, 110Vdc/ac, 1A	2788
Analog Input Module			
27	GT-3002	2ch load cell input unit, strain gauge	3002
28	GT-3114	4 Channels, 0~20, 4~20mA, 12bits, 10RTB	3114
29	GT-3154	4 Channels, 0~20, 4~20mA, 16bits, 10RTB	3154
30	GT-3118	8 Channels, 0~20, 4~20mA, 12bits, 10RTB	3118
31	GT-3158	8 Channels, 0~20, 4~20mA, 16bits, 10RTB	3158
32	GT-311F	16 Channels, 0~20, 4~20mA, 12bits, 20P connector	311F
33	GT-315F	16 Channels, 0~20, 4~20mA, 16bits, 20P connector	315F
34	GT-317F	16 Channels, 0~20, 4~20mA, 12bits, 18RTB	317F
35	GT-319F	16 Channels, 0~20, 4~20mA, 16bits, 18RTB	319F
36	GT-3424	4 Channels, 0~10, 0~5, 1~5Vdc, 12bits, 10RTB	3424
37	GT-3464	4 Channels, 0~10, 0~5, 1~5Vdc, 16bits, 10RTB	3464
38	GT-3428	8 Channels, 0~10, 0~5, 1~5Vdc, 12bits, 10RTB	3428

39	GT-3468	8 Channels, 0~10, 0~5, 1~5Vdc, 16bits, 10RTB	3468
40	GT-342F	16 Channels, 0~10, 0~5, 1~5Vdc, 12bits, 20P connector	342F
41	GT-346F	16 Channels, 0~10, 0~5, 1~5Vdc, 16bits, 20P connector	346F
42	GT-347F	16 Channels, 0~10, 0~5, 1~5Vdc, 12bits, 18RTB	347F
43	GT-349F	16 Channels, 0~10, 0~5, 1~5Vdc, 16bits, 18RTB	349F
44	GT-3704	4 Channels, RTD, 10RTB	3704
45	GT-3708	8 Channels, RTD, 20P connector	3708
46	GT-3804	4 Channels, Thermocouple, 10RTB	3804
47	GT-3808	8 Channels, Thermocouple, 20P connector	3808
48	GT-3714	4 Channels, TEMP. Controller, RTD Input, SSR Output	3714
49	GT-3734	4 Channels, TEMP. Controller, RTD Input, Current Output	3734
50	GT-3814	4 Channels, TEMP. Controller, TC Input, SSR Output	3814
51	GT-3834	4 Channels, TEMP. Controller, TC Input, Current Output	3834
52	GT-3901	AC Measurement	3901
53	GT-3914	4 Channels, Differential, 0~20, 4~20, +/-20mA, 12Bits, 10RTB	3914
54	GT-3934	4 Channels, Differential, 0~20, 4~20, +/-20mA, 16Bits, 10RTB	3934
55	GT-3918	8 Channels, Differential, 0~20, 4~20, +/-20mA, 12Bits, 18RTB	3918
56	GT-3938	8 Channels, Differential, 0~20, 4~20, +/-20mA, 16Bits, 18RTB	3938
57	GT-3924	4 Channels, Differential, 0~5, 0~10, +/-5, +/-10Vdc, 12Bits, 10RTB	3924
58	GT-3944	4 Channels, Differential, 0~5, 0~10, +/-5, +/-10Vdc, 16Bits, 10RTB	3944
59	GT-3928	8 Channels, Differential, 0~5, 0~10, +/-5, +/-10Vdc, 12Bits, 18RTB	3928
60	GT-3948	8 Channels, Differential, 0~5, 0~10, +/-5, +/-10Vdc, 16Bits, 18RTB	3948
Analog Output Module			
61	GT-4114	4CH, 0~20mA, 12Bits, 10RTB	4114
62	GT-4154	4CH, 0~20mA, 16Bits, 10RTB	4154
63	GT-4118	8CH, 0~20mA, 12Bits, 10RTB	4118
64	GT-4158	8CH, 0~20mA, 16Bits, 10RTB	4158
65	GT-4214	4 Channels, Current Output, 4~20mA, 12bits	4214
66	GT-4254	4 Channels, Current Output, 4~20mA, 16bits	4254
67	GT-4218	8 CHANNELS CURRENT OUTPUT, 4~20mA, 12BIT	4218
68	GT-4258	8 CHANNELS CURRENT OUTPUT, 4~20mA, 16BIT	4258
69	GT-4424	4CH, 0~10Vdc, 12Bits, 10RTB	4424
70	GT-4464	4CH, 0~10Vdc, 16Bits, 10RTB	4464
71	GT-4428	8CH, 0~10Vdc, 12Bits, 10RTB	4428
72	GT-4468	8CH, 0~10Vdc, 16Bits, 10RTB	4468
73	GT-442F	16CH, 0~10Vdc, 12Bits, 20P Connector	442F
74	GT-446F	6CH, 0~10Vdc, 16Bits, 20P Connector	446F
75	GT-447F	16CH, 0~10Vdc, 12Bits, 18RTB	447F
76	GT-449F	16CH, 0~10Vdc, 16Bits, 18RTB	449F
77	GT-4524	AO 4 CHs, ±10Vdc, 12Bits, 10RTB	4524
78	GT-4564	AO 4 CHs, ±10Vdc, 16Bits, 10RTB	4564
Special Module			
79	GT-5102	2CH, Encoder, Input, 5Vdc, 10RTB	5102
80	GT-5112	High Speed Counter, 2CHs, 24Vdc, Encoder Input, 10RTB	5112
81	GT-5114	High Speed Counter, 4CHs, 24Vdc, Encoder Input, 10RTB	5114
82	GT-5211	1CH, RS 232, RTS/CTS, Full Duplex Type, 10RTB	5211
83	GT-5212	2CH, RS 232, Full Duplex Type, 10RTB	5212
84	GT-5221	1CH, RS 485, Full Duplex Type, 10RTB	5221

85	GT-5231	1CH, RS 485, Half Full Duplex Type, 10RTB	5231
86	GT-5232	2CH, RS 485, Half Full Duplex Type, 10RTB	5232
87	GT-5352	2CH, Synchronous Serial Interface Input, 10RTB	5352
88	GT-5442	PWM Output, 2CHs, 0.5A/24Vdc, Source, 18RTB	5442
89	GT-5444	PWM Output, 4CHs, 0.5A/24Vdc, Source, 18RTB	5444
90	GT-5642	Pulse Output, 2CHs, 0.5A/24Vdc, Source, 18RTB	5642
91	GT-5652	Pulse Output, 2CHs, RS422 (Differential), 18RTB	5652
92	GT-5521	1CH, Stepper Module (TBD)	5521
Power Module			
93	GT-7408	Shield Module	7408
94	GT-7508	Common for 0Vdc	7508
95	GT-7511	Power Expansion, In 24Vdc, Out 1A/5Vdc	7511
96	GT-7518	Common for 24Vdc	7518
97	GT-7588	Common for 0Vdc, 24Vdc	7588
98	GT-7641	Field Power, 5/24/48 Vdc, 110/220 Vac	7641
99	GT-7151	Noise Filter Module, 18RTB, None ID Type	7151
100	GT-7851	Noise Filter Module, 18RTB, ID Type	7851

A.2. Glossary

- System Power : The power for starting up CPU.
- Field Power : The power for input and output line.
- Terminator Resistor : Resistor for prevention reflected wave.
- EDS : Electronic Data Sheet.
- Sink : The method of in/output power supply if a device has no power source.
- Source : The method of in/output power supply if a device has the power source.