



Features

- 19" Intel® 8th Generation Fanless Stainless Panel PC
- IP66/69K Full Sealed with Anti-Corrosion Enclosure
- Support Intel® vPro Technology by CPU
- IP67 M12 Stainless/Metal Connectors
- Special Inspection of 100% Waterproof Guarantee
- CE, FCC, VCCI Class B Certified

Specification

Product		WTP-9G66-19	
Main System	CPU	Intel® 8th Gen (Whiskey lake-U) Core™ MCP Processor, 15 W	
	Graphic	Intel® UHD Graphics 620	
	Memory	Dual channel support 2666MHz DDR4 SODIMM socket x 2, up to 32GB	
	OS Support	Windows 10 (64 bit) / Windows 11 (64 bit)	
Display	Size	19" 5:4	
	Resolution (pixel)	1280 x 1024 (SXGA)	
	Number of Colors	16.7M colors (RGB 6-bit + Hi FRC)	
	View Angle (H/V)	170(H) / 160(V)	
	Brightness (nit)	350 nits	
	Contrast Ratio	1000:1 (Typ)	
Touch Panel	Type	Full flat resistive touch	Full flat p-cap touch
	Light Transmission	80 ± 5%	90 ± 3%
	Hardness/ Lifetime	≥ 3H / 35M times	7H / 100M times
Storage & Expansion	Storage	2.5" SATA HDD or SSD M.2 (Key M, 2242/2260/2280) for SSD x 1	
	Expansion	M.2 Type E x 1 for wireless x 1	
I/O Ports	Configuration	STD. (M12 Connector)	Cable Gland (Max. 5 external I/O by proper grommet)
	USB	1 x M12 8pin for USB2.0 1/2 1 x M12 8pin for USB 2.0 3/4	USB 3.1 x 4
	COM	2 x M12 8pin for COM 1/COM2 / RS-232/422/485	RS232/RS422/RS485 x 2
	LAN	1 x M12 8pin for LAN x 1 (i219LM for Vpro)	RJ-45 x 2 (Gigabit Ethernet)
	Audio	N.A.	3.5mm phone jack connector * 2 (Line-out, and Mic-in)
	Video	N.A.	HDMI 2.0a x 1, DP1.2 x 1
	DC in	1 x M12 5pin DC power connector, DC19~28	
	Control Keys	Rear bottom: Power on /off	
Power	Power adapter	AC 100 ~ 277V / 47 ~ 63 Hz / DC output 24V, 5A, 120W, IP68	
	Power consumption	90 W	
Environmental	Temperature	Operating Temperature 0°C~40°C/ 0~50°C (change to SSD) Storage Temperature -20°C~60°C	
	Humidity	Operating & Storage: 10 ~ 90%, non-condensing	
	Water/Dust resistance	IP66 / NEMA4X / IP69K whole set	
Mechanical Characteristics	Housing	Stainless steel (SUS304), chassis type	
	Dimensions (Net: mm)	458 x 386 x 64	
	Weights (Net: kg)	11.5 kg	
	Mounting	VESA 100*100, side mount (M6*2)	
Certification	CE (EMC) :EN61000-6-4 ; EN61000-6-2 / FCC/VCCI Class B, Canada ICES-003		

WTP-9G66-19

Stainless Steel Panel PC

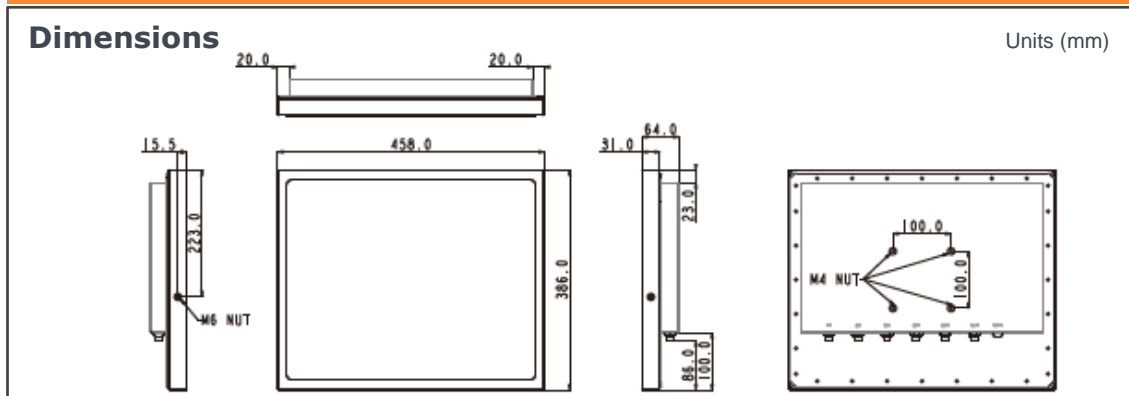

Major Options

Options	<ol style="list-style-type: none"> 1.Full flat PCT touch screen IP69K 2.IP67 3.2.5" SSD 4.Wireless or Wireless and BT kit (easy clean and Robust Antenna) 5.2 External LAN(USBx2,LANx2,COMx1) 6.Stainless M12 connector 7.SUS316 enclosure 8.2nd HDD for RAID 0,1 9.Cable gland external IO 10.Windows 10 (64bit) or Windows 11 (64 bit) 11.DC power extension cable (2m)
Accessory	<ol style="list-style-type: none"> 1.Waterproof USB cable, cable length is 2 meters 2.Waterproof LAN cable, cable length is 2 meters 3.Waterproof COM cable, cable length is 2 meters 4.wall mount / table mount bracket 5.DC input cable
Customization	<ol style="list-style-type: none"> 1.Sunlight readable optical bonding 2.Roof for UV protection and sunlight readable 3.1000 nit high brightness LCD 4.5W/2W Speaker 5.Barcode reader 6.COM + Power 5V or 12V 7.M.2 SSD 8.TPM 2.0 or FTPM 9.M.2 (Key B, 3042) with USB2.0 and SIM for 4G x 1 10.Waterproof USB3.0 11.Intel i3-8145UE, DC, 2.2GHz 12.WDT AP/API

Order Information

Item	Cooling	Description
WTP-9G66-19 (i5)	Fanless	19" Core i5-8365UE / DDR4 4G RAM/ 500G HDD/ Full Flat R-touch
WTP-9G66-19 (i5)	Fanless	19" Core i5-8365UE / DDR4 4G RAM/ 500G HDD/ Full Flat P-cap touch

I/O ports



- 1 Giga LAN
- 2 USB 1/2
- 3 USB 3/4
- 4 COM x 2
- 5 DC-in
- 6 Power on/off

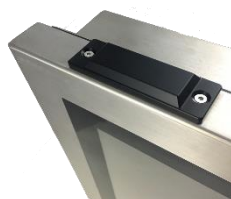

Wireless or Wireless + BT kit
(Easy Clean and Robust Antenna)



Cable Gland for External I.O. (Optional)