



Features

- 15" Intel® 8th Generation Fanless Stainless Panel PC
- IP66/69K Full Sealed with Anti-Corrosion Enclosure
- Support Intel® vPro Technology by CPU
- IP67 M12 Stainless/Metal Connectors
- Optional Cable Gland for External I.O.
- 100% Waterproof Guarantee
- CE, FCC, VCCI Class B Certified

Specification

Product		WTP-9G66-15	
Main System	CPU	Intel® 8th Gen (Whiskey lake-U) Core™ MCP Processor, 15 W	
	Graphic	Intel® UHD Graphics 620	
	Memory	Dual channel support 2666MHz DDR4 SODIMM socket x 2, up to 32GB	
	OS Support	Windows 10 (64 bit) / Windows 11 (64 bit)	
Display	Size	15" 4:3	
	Resolution (pixel)	1024 x 768 (XGA)	
	Number of Colors	16.2M colors (RGB 6-bit + Hi FRC)	
	View Angle (H/V)	160(H) / 160(V)	
	Brightness (nit)	350 nits	
	Contrast Ratio	800 : 1 (Typ)	
Touch Panel	Type	Full flat resistive touch	Full flat p-cap touch
	Light Transmission	80 ± 5%	≥86%
	Hardness / Lifetime	≥3H / 35M times	≥7H / 100M times
Storage & Expansion	Storage	2.5" SATA HDD or SSD, M.2 (Key M, 2242/2260/2280) for SSD x 1	
	Expansion	M.2 Type E x 1 for wireless x 1	
I/O Ports	Configuration	STD. (M12 Connector)	Cable Gland (Max. 5 external I/O by proper grommet)
	USB	1 x M12 8pin for USB 2.0 1/2 1 x M12 8pin for USB 2.0 3/4	USB 3.1 x 4
	COM	2 x M12 8pin for COM 1 & COM2 / RS-232/422/485	RS232/RS422/RS485 x 2
	LAN	1 x M12 8pin for LAN x 1 (i219LM for Vpro)	RJ-45 x 2 (Gigabit Ethernet)
	Audio	N.A.	3.5mm phone jack connector * 2 (Line-out, and Mic-in)
	Video	N.A.	HDMI 2.0a x 1, DP1.2 x 1
	DC in	1 x M12 5pin DC power connector, DC 19~28V	
	Control Keys	Rear bottom: Power on /off	
Power	Power adapter	AC 100 ~ 277V / 47 ~ 63 Hz / DC output 24V, 5A, 120W, IP68	
	Power consumption	83.9 W	
Environmental	Temperature	Operating Temperature 0~40°C / 0~50°C(change to SSD) Storage Temperature -20~60°C	
	Humidity	Operating & Storage: 10 ~ 90%, non-condensing	
	Water/Dust resistance	IP66 / NEMA4X / IP69K whole set	
Mechanical Characteristics	Housing	Stainless steel (SUS304), chassis type	
	Dimensions (Net: mm)	395 x 309.5 x 58	
	Weights (Net: kg)	8.4 kg	
	Mounting	VESA 100*100, side mount (M6*2)	
Certification	CE (EMC) :EN61000-6-4 ; EN61000-6-2 / FCC/VCCI Class B, Canada ICES-003		

WTP-9G66-15

Stainless Steel Panel PC

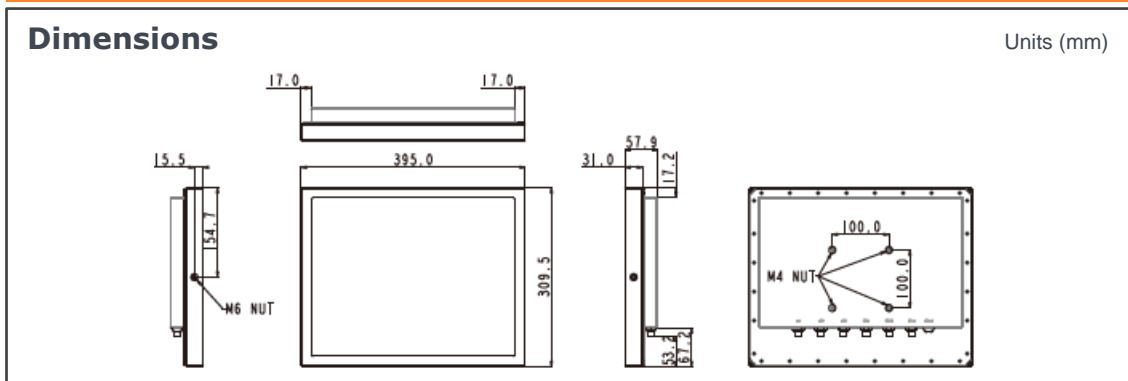

Major Options	
Options	<ol style="list-style-type: none"> 1. Full flat PCT touch screen IP69K 2. IP67 3. 2.5" SSD 4. Wireless or Wireless and BT kit (easy clean and Robust Antenna) 5. 2 External LAN(USBx2,LANx2,COMx1) 6. Stainless M12 connector 7. Cable gland external IO 8. SUS316 enclosure 9. Windows 10 (64bit) or Windows 11 (64bit) 10. DC power extension cable (2m)
Accessory	<ol style="list-style-type: none"> 1. Waterproof USB cable, cable length is 2 meters 2. Waterproof LAN cable, cable length is 2 meters 3. Waterproof COM cable, cable length is 2 meters 4. Wall mount / table mount bracket 5. DC input cable
Customization	<ol style="list-style-type: none"> 1. Sunlight readable optical bonding 2. Roof for UV protection and sunlight readable 3. 1000 nit high brightness LCD 4. 5W/2W Speaker 5. Barcode reader 6. COM + Power 5V or 12V 7. 2nd HDD for RAID 0,1 8. M.2 SSD 9. TPM 2.0 or FTPM 10. M.2 (Key B, 3042) with USB2.0 and SIM for 4G x 1 11. Waterproof USB3.0 12. Intel i3-8145UE, DC, 2.2GHz 13. WDT AP/API

Order Information

Item	Cooling	Description
WTP-9G66-15 (i5)	Fanless	15" Core i5-8365UE / DDR4 4G RAM/ 500G HDD/ Full Flat R-touch
WTP-9G66-15 (i5)	Fanless	15" Core i5-8365UE / DDR4 4G RAM/ 500G HDD/ Full Flat P-cap touch

I/O ports

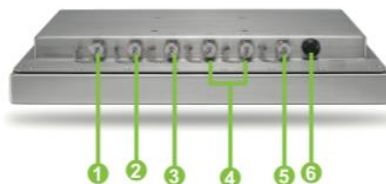

- 1 Giga LAN
- 2 USB 1/2
- 3 USB 3/4
- 4 COM x 2
- 5 DC-in
- 6 Power on/off

