



### Features

- Smart Fan OUTDOOR Panel PC
- Intel® Quad Core E3845 Wide Temp. CPU
- IP69K Full Sealed SECC Enclosure
- 15" 1000nits Sunlight Readable LCD
- Optical Bonding with Anti-UV Coating
- P-cap Touch with AR Glass Treatment
- Wide Temp. -20~60°C Operation Capability
- M12 IP67 Connectors
- CE, FCC, VCCI Class B Certified

### Specification

Product		WTP-8B66-150
Main System	CPU	Intel Atom E3845 processor 10W
	Graphic	Intel® Graphics HD
	Memory	Wide Temp. Two DDR3 SODIMM socket support up to 8GB
	OS Support	Win7 32Bit, Win7 64Bit, Win8 32Bit, Win8 64 Bit, and Win10 64 Bit
Display	Size	15" 4:3
	Resolution (pixel)	1024 x 768 (XGA)
	View Angle (H/V)	160(H) / 140(V)
	Brightness(cd/m <sup>2</sup> , nit)	1000 nits
	Contrast Ratio	700 : 1 (Typ)
Touch Panel	Type	Full Flat P-cap touch / Light Transmission: 91%
	Light Transmission	91%
	Lifetime	50M times
Storage & Expansion	Storage	Wide Temp. 128GB 2.5" SATA SSD x 1
	Expansion	Mini PCIe*1 52 pin card-edge type x 2 support half / full size
I/O Ports	USB	1 x M12 8pin for USB 1/2, 1 x M12 8pin for USB 3/4
	COM	1 x M12 8pin for COM 1/RS-232/422/485 (Default RS-232) 1 x M12 8pin for COM 2/RS-232
	LAN	1 x M12 8pin
	DC in	1 x M12 5pin DC power connector
	Control Keys	Rear bottom: Power on /off
Power	Power input	DC 7V~32V
	Power adapter	AC100~277V/ 47 ~ 63 Hz / DC output 24V / IP68
	Power consumption	40.9 W
Environmental	Temperature	<ul style="list-style-type: none"> <li>● Operating Temp. Low temp: -20°C / High temp (IEC-60068-2-5): 1120W/m2 solar energy: 45°C / 900W/m2 solar energy: 51°C / Air flow (Semi-Outdoor): 60°C</li> <li>● Storage Temperature -20~65°C</li> </ul>
	Humidity	Operating & Storage: 10 ~ 90%, non-condensing
	Water/Dust resistance	IP69K whole set
Mechanical Characteristics	Housing	SECC power coating, light color, full flat chassis type
	Dimensions (Net: mm)	415 x 329.5 x 85
	Weights (Net: kg))	10.2 kg
	Mounting	VESA 100/100, Side Mount (M6*2)
Certification	CE/ FCC/ VCCI Class B, Canada ICES-003	

# WTP-8B66-150

# Rugged High Brightness Panel PC

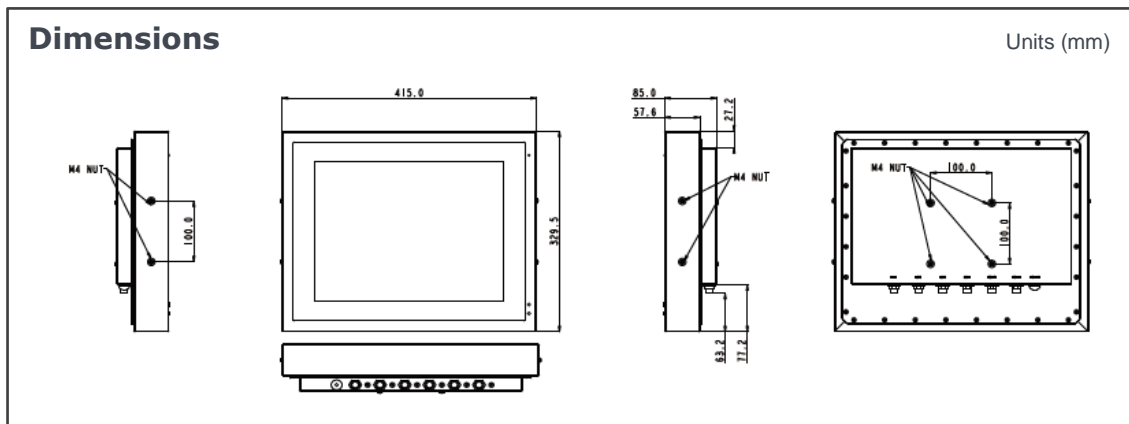

Major Options	
Add On Parts	1. Wireless or WIFI and BT kit (Robust Antenna) 2. LAN x 2 (COM x1, LAN x 2, USB x2) 3. TPM 2.0
Power Cable	1. Waterproof COM cable x 1, 2M 2. Waterproof USB cable x 1, 2M 3. Waterproof LAN cable x1, 2M 4. Maximum length is 7.2 meters by 3x2m DC cables
Customized	1. COM + Power 5V / 12V, 2. Stainless Steel M12 Connector 3. Barcode Reader , 4. 5W/2W Speaker, 5. USB3.0

## Order Information

Item	Cooling	Description
WTP-8B66-150	Smart Fan	15" E3845/wide temp. 2G RAM/ 128G SSD/ 4 USB, 2 COM, 1 LAN

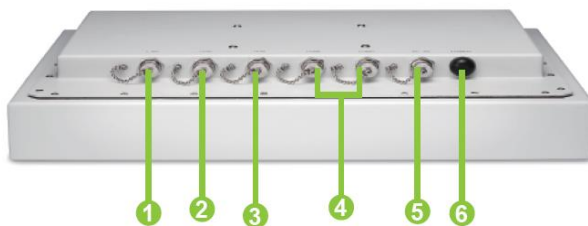

- ① Giga LAN
- ② USB 1/2
- ③ USB 3/4
- ④ COM x 2
- ⑤ DC-in
- ⑥ Power on/off

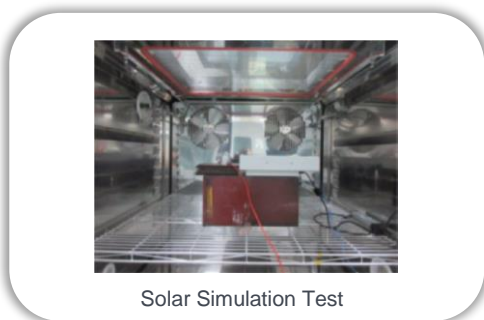

**IP SYSTEMES**  
 8 rue du Colonel Chambonnet – BP67  
 69672 BRON Cedex  
 Tel. : 04 72 14 18 00  
 Fax : 04 72 14 18 01  
[www.ip-systemes.com](http://www.ip-systemes.com) – [info@ip-systemes.fr](mailto:info@ip-systemes.fr)