



HRT-710 / HRT-710-UTA

Modbus RTU/ASCII to HART Gateway

Features

- Support HART Short/Long frame
- Support HART Burst mode
- Allow two HART Masters
- Working in point-to-point or multi-drop HART mode
- Connecting up to 15 HART modules
- Support Modbus RTU and ASCII format
- Support Modbus Slave mode
- Isolated COM 1: RS-232/422/485
- Provide LED indicators
- 4KV ESD Protection



Introduction

The HRT-710 Gateway is specially designed for the master device of HART protocol. It allows the Modbus master device to access the HART slave devices. These HART devices may be a transmitter, an actuator, a current output device and so forth. In addition, we also provide the utility software for users to configure the HRT-710. By using this module, users can integrate their HART devices into Modbus network easily.

Modbus Support

- Support the following Modbus commands

Code	Name	Description
01	Read Coil Status	Read the ON/OFF status of discrete outputs in the slave
02	Read Input Status	Read the ON/OFF status of discrete inputs in the slave
03	Read Holding Registers	Read the binary contents of holding registers in the slave
04	Read Input Registers	Read the binary contents of input registers in the slave
05	Force Single Coil	Write a single output to either ON or OFF in the slave
06	Preset Single Register	Write an integer value into a single register in the slave
15	Force Multi. Coils	Write each coil in the sequence of coils to either ON or OFF in the slave
16	Preset Multi. Registers	Write a block of contiguous registers in the slave

Utility Features

- Read/Write HART device by HART command
- Provide diagnostic Information
- Read/Write module configuration of the HRT-710
- Show Modbus address of HART command

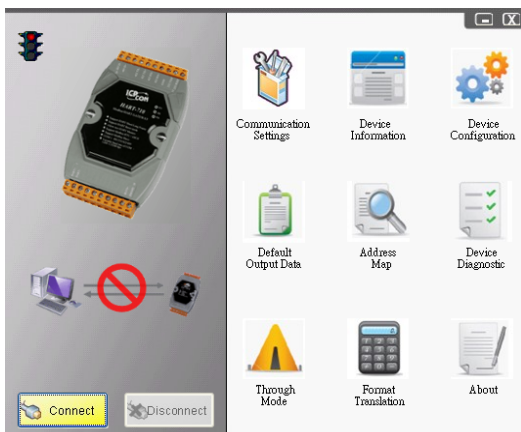

Pin Assignments

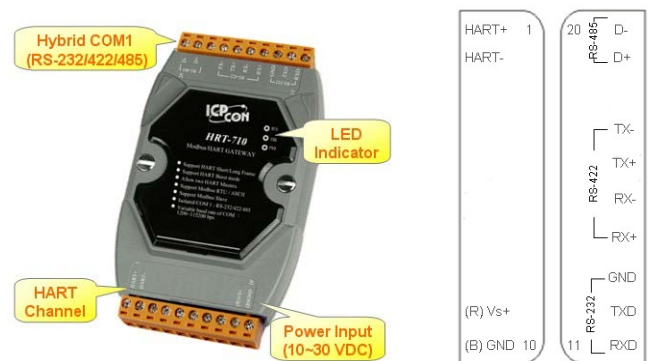

Dimensions (Units: mm)

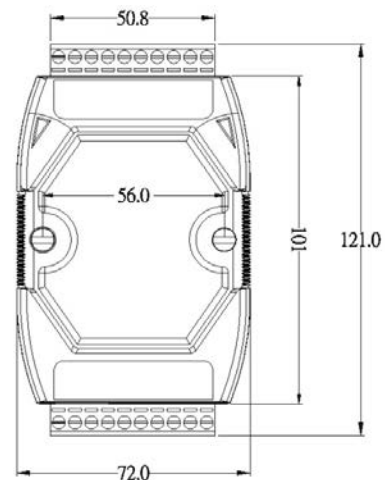

Hardware Specifications

Hardware	
Watchdog	Watchdog IC
ESD Protection	4 kV class A
UART Interface	
COM 1	RS-232(3 wire)/RS-422/RS-485
COM 1 Connector	9-pin screwed terminal block
Baud Rate (bps)	1200, 2400, 4800, 9600, 19200, 38400, 57600, 115200
Protocol	Modbus RTU / Modbus ASCII
HART Interface	
HART Channel	1
HART Interface	2-pin screwed terminal block
HART Device	2-wired or 4-wired HART devices
HART Topology	Point to Point or Multi-Drop
HART Data	Only Digital Data
HART Frame Type	Short and Long Frame
Burst Mode	Supported
Max. HART Device	15
Loop Resistor	250 Ω resistor by Jumper
Isolation	Follow UL1577 Spec.
Power	
Power supply	Unregulated +10 ~ +30 VDC
Protection	Power reverse polarity protection, Over-voltage brown-out protection
Power Consumption	1 W
Mechanism	
Installation	DIN-Rail or Wall Mounting
Dimensions	72 mm x 35 mm x 121 mm (W x L x H) Detail
Environment	
Operating Temp.	HRT-710: -25 ~ +75 °C HRT-710-UTA: -40 ~ +75 °C
Storage Temp.	HRT-710: -30 °C ~ +80 °C HRT-710-UTA: -40 ~ +80 °C
Humidity	10% ~ 90% RH, non-condensing

Application

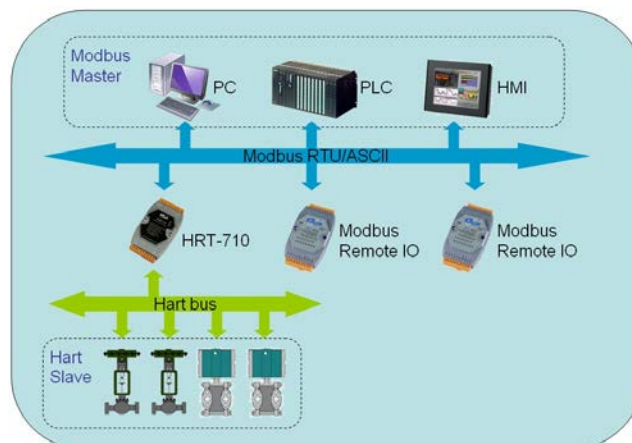

Ordering Information

HRT-710 CR	Modbus RTU/ASCII to HART Gateway (RoHS)
HRT-710-UTA CR	Modbus RTU/ASCII to HART Gateway (-40°C Application), (RoHS)