

EtherNet/IP to Modbus RTU/TCP Gateway

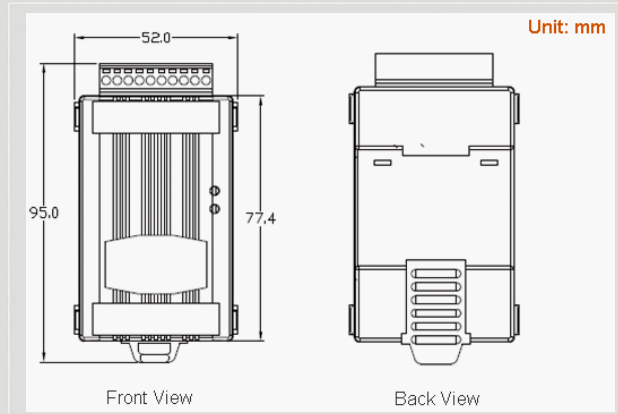

GW-7472



Dimensions

The GW-7472 (EtherNet/IP adapter to Modbus RTU Master/TCP Client Gateway) is helpful for data-exchanging between the Modbus RTU/TCP network, and the EtherNet/IP network. It reads the register data from the Modbus RTU slaves as well as Modbus TCP servers and publishes these data to the input register data of the EtherNet/IP scanner. The output data transmitted by the EtherNet/IP scanner are updated to the register data of Modbus RTU slaves/TCP servers via the GW-7472. Through the GW-7472, all of the Modbus slaves/servers can be regard as one EtherNet/IP adapter.

Features

- Powerful 32-bit MCU handles efficient network trafficking
- Tiny form-factor and low power consumption
- Made from fire retardant materials (UL94-V0 Level)
- Supports TCP, UDP, DHCP, BOOTP and TFTP protocols
- Ethernet Protocol: EtherNet/IP Adapter
- Modbus Protocol: Modbus RTU Master/Modbus TCP Client
- Maximum support 30 Modbus RTU commands
- Maximum support 10 Modbus TCP Servers
- Support 8 Modbus TCP commands for each TCP servers
- Maximum EtherNet/IP Input/Output data size: 500 bytes

Utility Features

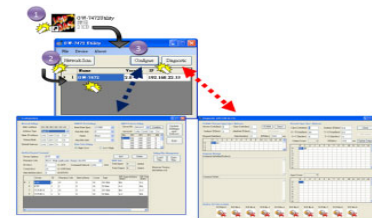

- Network parameters configuration
- UART parameters configuration
- Modbus devices configuration
- Auto search GW-7472 device
- Easy test to transmit/receive EtherNet/IP data

Modbus RTU Command Support

Function code.	Description
01 (0x01)	Read Coil Status
02 (0x02)	Read Input Status
03 (0x03)	Read Holding Registers
04 (0x04)	Read input Registers
15 (0x0F)	Force Multi Coils
16 (0x10)	Preset Multi Registers

Wire Connection

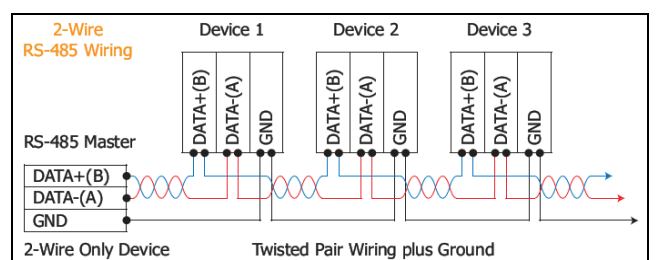
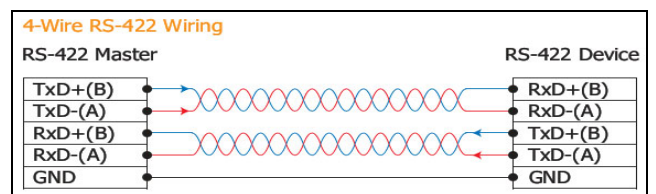



Hardware Specifications

Hardware	
CPU	32-bit MCU
UART Interface	
COM 1	2-wire RS-485 4-wire RS-422
COM 1 Connector	10-Pin Removable Terminal Block x 1
Protocol	Modbus RTU master
Ethernet Interface	
Ethernet	10/100 Base-TX, 8-pin RJ-45 x 1, (Auto-negotiating, Auto-MDI/MDIX, LED indicator) PoE (IEEE 802.3af, Class 1)
Protocol	EtherNet/IP adapter and Modbus TCP client
Power	
Power supply	PoE: IEEE 802.3af, Class 1 DC jack: +12 ~ 48 V _{DC}
Power Consumption	0.05 A @ 24 V _{DC}
Mechanism	
Dimensions	52mm x 95mm x 27mm (W x L x H)
Mounting	DIN-Rail
Flammability	Fire Retardant Materials (UL94-V0 Level)
Environment	
Operating Temperature	-25 ~ 75 °C
Storage Temperature	-30 ~ 80 °C
Humidity	10 ~ 90% RH, non-condensing

Application

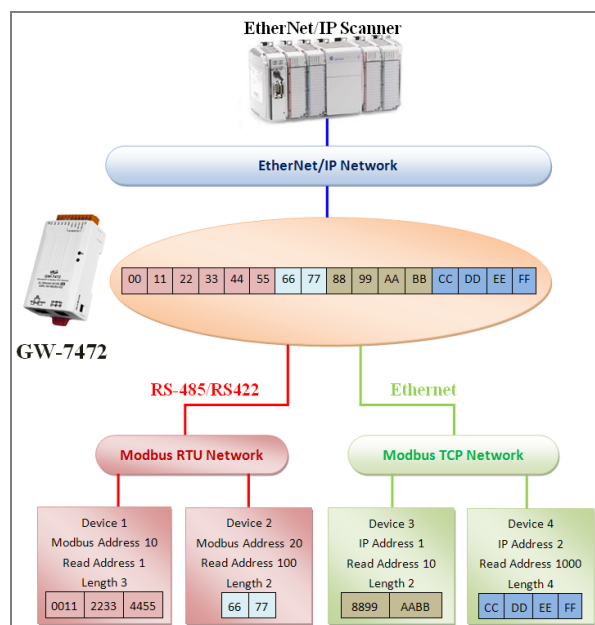
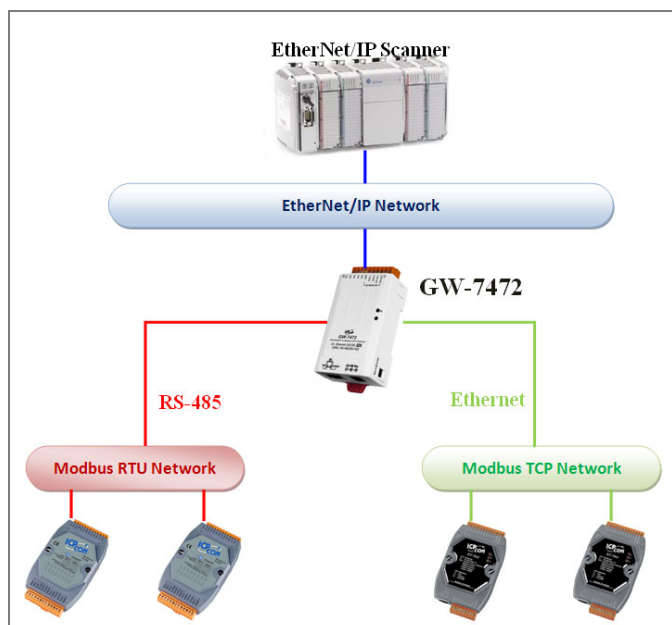

Ordering Information

GW-7472 CR EtherNet/IP to Modbus RTU/TCP gateway with PoE and one RS-422/485 (RoHS)