

## Modbus TCP Server/RTU Slave to CANopen Master Gateway RoHS CE FC

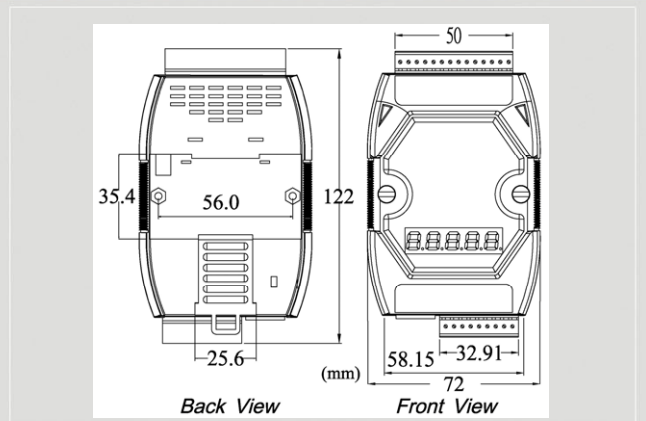

**GW-7433D**



**Dimensions**

The GW-7433D is a solution that provides a communication transformation between CANopen protocol and Modbus/TCP protocol. It solves a mission-critical problem, and connecting an existed CANopen network with Ethernet-base master device as long as this master device supports Modbus/TCP protocol. It enables CANopen networks to be coupled together with the Internet/Ethernet, whereby remote monitoring and controlling is achieved.

### Features

- Follow the CiA CANopen Standard DS-301 v4.02
- Provide listen mode
- Support Max 10 CANopen Slave modules
- Support Node Guarding and Heartbeat Consumer protocol
- Support more than 120 CANopen SDO/PDO commands
- Support 4 data types: Boolean、Byte、Word、4-byte
- Provide the CANopen disconnection detection
- Allow to get the CAN status by Modbus commands

### Modbus TCP Command Support

Function code.	Description
01 (0x01)	Read Coil Status
02 (0x02)	Read Input Status
03 (0x03)	Read Holding Registers
04 (0x04)	Read input Registers
05 (0x05)	Force Single Coils
06 (0x06)	Preset Single Register
15 (0x0F)	Force Multi Coils
16 (0x10)	Preset Multi Registers

### Utility Features

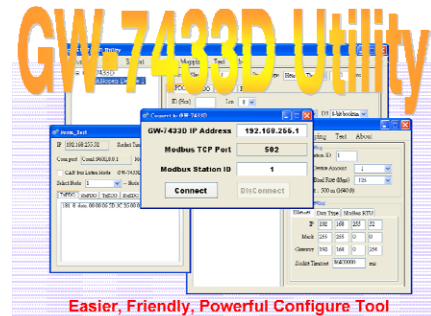

Easier, Friendly, Powerful Configure Tool

- Add/remove CANopen slaves via Ethernet
- Get/Set Modbus/TCP input/output memory address
- Display CANopen I/O mapping table
- Add/remove CANopen slaves via Ethernet

### Pin Assignments

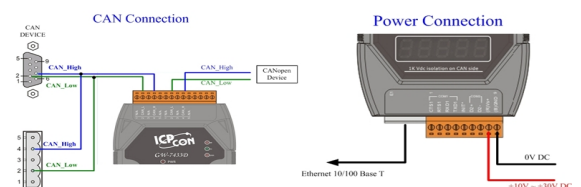

### Design Flowchart

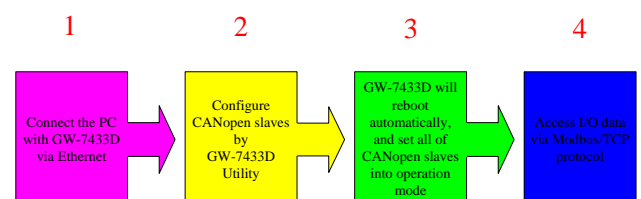



## Hardware Specifications

Hardware	
CPU	80186, 80 MHz or compatible
Watchdog	Watchdog IC
CAN Interface	
Controller	NXP SJA1000T with 16 MHz clock
Transceiver	NXP 82C250
Connector	5-pin screwed terminal block (CAN_L, CAN_SHLD, CAN_H, N/A for others)
Isolation	1000 V <sub>DC</sub> for DC-to-DC, 2500 Vrms for photo-couple
Protocol	CANopen DS-301 ver4.02
UART Interface	
COM 1	RS-232
COM 1 Connector	5-pin screwed terminal block (TxD, RxD, RTS, CTS, GND)
COM 2	RS-485 (Self-turner inside)
COM 2 Connector	2-pin screwed terminal block (DATA+, DATA-)
Protocol	Modbus RTU
Ethernet Interface	
Controller	10/100Base-TX Ethernet Controller (Auto-negotiating, Auto_MDIX)
Connector	RJ-45 with LED indicator
Protocol	Modbus TCP
Power	
Power supply	Unregulated +10 ~ +30 V <sub>DC</sub>
Protection	Power reverse polarity protection, Over-voltage brown-out protection
Power Consumption	2.5 W
Mechanism	
Dimensions	72mm x 33mm x 122mm (W x L x H)
Environment	
Operating Temp.	-25 ~ 75 °C
Storage Temp.	-30 ~ 80 °C
Humidity	10 ~ 90% RH, non-condensing

## Application

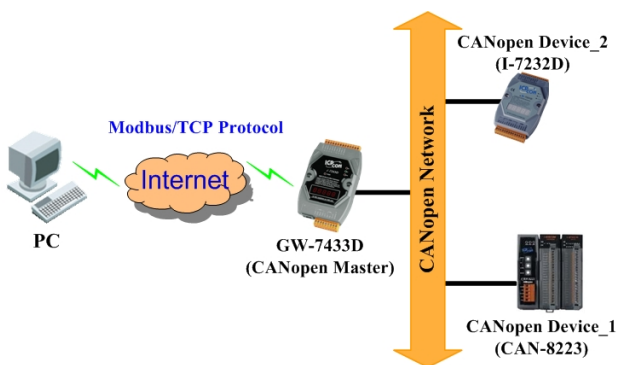

## 5-digit 7-Segment LED Display

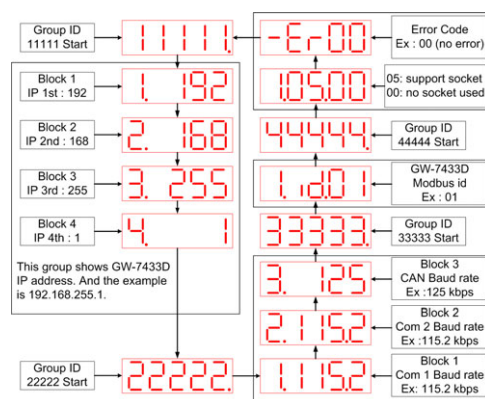

## LED indicators

LED	Description
MI	The led provides the Modbus/TCP protocol is act or not
CI	This led indicates the CANopen communication status of the module
ERR	This led indicates the CANopen status of the GW-7433D

## Ordering Information

<b>GW-7433D CR</b>	Modbus TCP Slave/CANopen Master Gateway (RoHS)
--------------------	--