



## GW-7238D

J1939 to Modbus TCP Server / RTU Slave Gateway

### Introduction

The GW-7238D is a gateway that provides conversion between J1939 and Modbus TCP/RTU protocol. For J1939 network, the GW-7238D supports PDU1, PDU2, broadcast and destination specific type of J1939 messages. For Modbus TCP/RTU network, the GW-7238D is a Modbus TCP server / RTU slave to reply the request from Modbus TCP client / RTU master. Utility software is provided for users to configure J1939 and Modbus TCP/RTU setting in the GW-7238D. The application fields can be Diesel power-train applications, In-Vehicle networks for trucks and buses, etc.

### Hardware Specifications

Hardware	
CPU	80186, 80 MHz or compatible
CAN Interface	
Controller	NXP SJA1000T with 16 MHz clock
Channel number	1
Connector	5-pin screwed terminal block (CAN_L, CAN_H, N/A for others)
Baud Rate (bps)	250 k
Isolation	1000 V <sub>DC</sub> for DC-to-DC, 2500 Vrms for photo-couple
Terminal Resistor	Jumper for 120 Ω terminal resistor
Specification / Protocol	ISO-11898-2, CAN 2.0A and CAN 2.0B / J1939
UART Interface	
COM 1 / Protocol	RS-232 / Modbus RTU
COM 1 Connector	5-pin screwed terminal block (TxD, RxD, RTS, CTS, GND)
COM 2 / Protocol	RS-485 (Self-turner inside) / Modbus RTU
COM 2 Connector	2-pin screwed terminal block (DATA+, DATA-)
Ethernet Interface	
Controller	10/100Base-TX Ethernet Controller (Auto-negotiating, Auto_MDIX)
Connector / Protocol	RJ-45 with LED indicator / Modbus TCP
LED	
Round LED	PWR / J1939 / MODBUS RTU / MODBUS TCP
Power	
Power supply	Unregulated +10 ~ +30 V <sub>DC</sub>
Protection	Power reverse polarity protection, Over-voltage brown-out protection
Power Consumption	3 W

### Features

- Provides PWR / J1939 / MODBUS indication LEDs
- Built-in jumper to select 120 ohm terminal resistor
- Watchdog inside
- Transmission and reception of all types of J1939 messages, including PDU1, PDU2, broadcast and destination specific
- J1939 Transport Protocol for transmission and reception of large messages (9 - 1785 bytes)
- Supports BAM of Connection Management Message
- Network addresses management
- Supports RS-232, RS-485 and Ethernet interfaces
- Configurable baud rates of 2400, 4800, 9600, 19200, 38400, 57600, 115200 bps
- Supports Modbus TCP server / RTU slave protocol



Mechanism	
Dimensions	108mm x 72mm x 35mm (H x W x D)
Environment	
Operating Temp.	-25 ~ 75 °C
Storage Temp.	-30 ~ 80 °C
Humidity	10 ~ 90% RH, non-condensing

### Utility Features

- Provides Modbus network configuration interface
- Provides J1939 network configuration interface – Network Address / Device Name...
- Provides J1939 Input / Output configuration interface

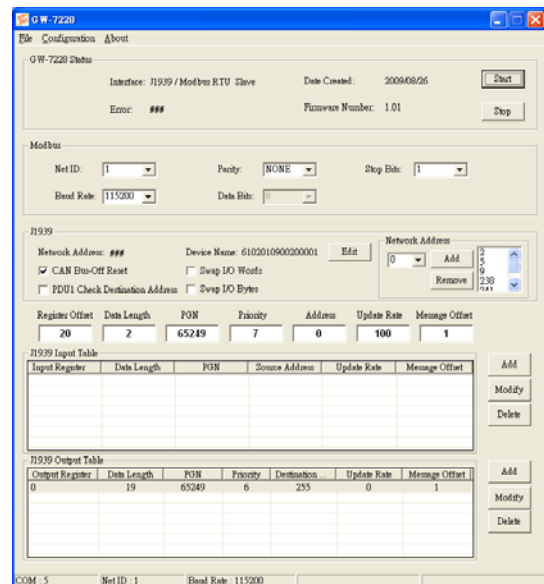

## Wiring and Pin Assignments

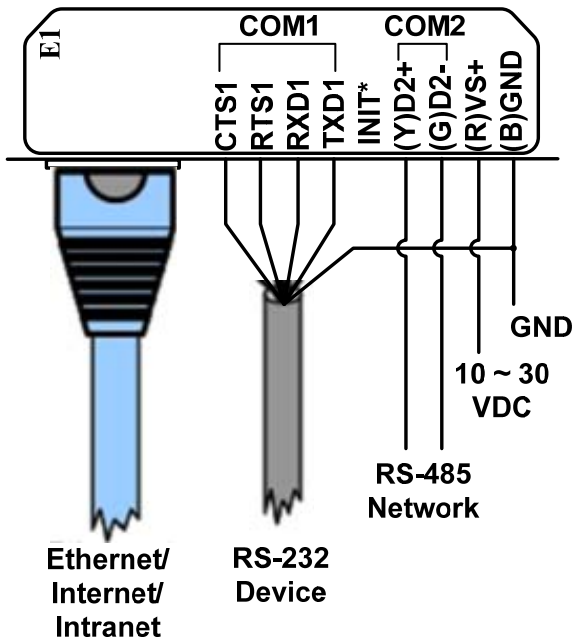
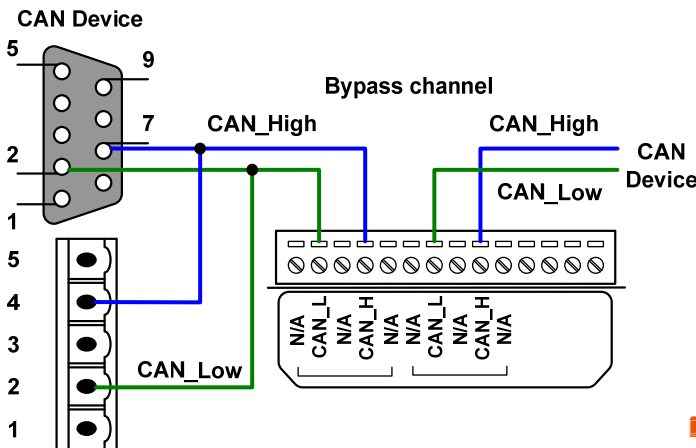

## Dimensions (Units: mm)

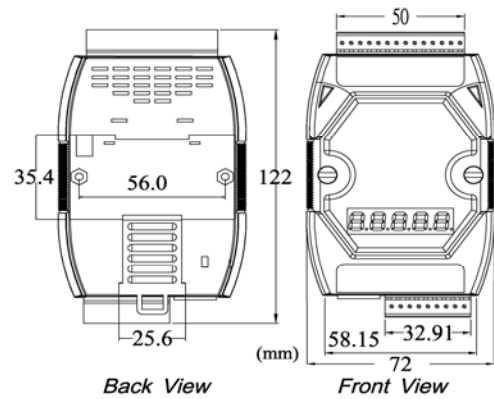

## Block Diagram

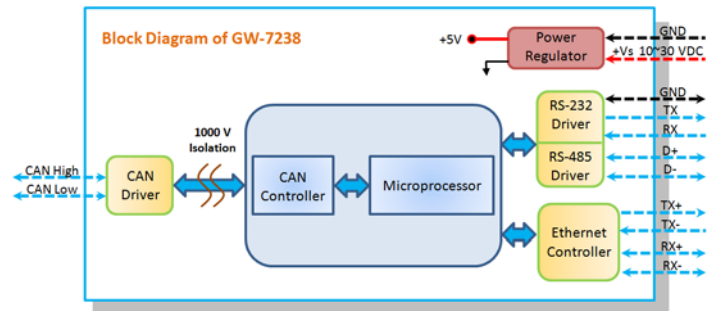

## Application

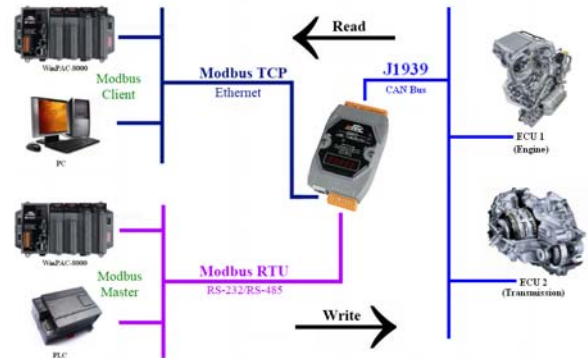

## Ordering Information

**GW-7238D CR**

J1939 to Modbus TCP Server / RTU Slave Gateway included CA-0910 cable(RoHS)



**IP SYSTEMES**

8 rue du Colonel Chambonnet – BP67

69672 BRON Cedex

Tel. : 04 72 14 18 00

Fax : 04 72 14 18 01

[www.ip-systemes.com](http://www.ip-systemes.com) – [info@ip-systemes.fr](mailto:info@ip-systemes.fr)