

# M133K

13.3" Intel® Core™ i5-7200U Ultra Rugged Tablet PC



## KEY FEATURES

- Intel® Core™ i5-7200U Kaby Lake processor
- 13.3" 1920 x 1080 wide viewing angle LED Panel
- Magnesium alloy housing with all-around elastomeric rubber
- Built-in kickstand
- IP65 waterproof and dustproof
- With optical bonding to increase optical clarity and readability



## SPECIFICATIONS

Display	
<b>Resolution</b>	1920x1080
<b>Contrast Ratio</b>	1000:1
<b>View Angles</b>	89,89,89,89
<b>Bonding</b>	Optical Bonding for Sunlight Viewability
<b>Size</b>	13.3 inches
<b>Panel Brightness</b>	500 nits
<b>Type</b>	Projected Capacitive Multi Touch
System Specification	
<b>Processor</b>	Intel® Core™ i5-7200U Kaby Lake, 2.5 GHz (Turbo up to 3.10 GHz)
<b>Memory</b>	4GB SODIMM DDR4-2400 8GB SODIMM DDR4-2400 (Optional) 16GB SODIMM DDR4-2400 (Optional)
<b>Storage</b>	Storage 1: 1 x 128GB M.2 SSD Additional storage available with SDXC card slot Storage 1 up to 1x 1TB M.2 SSD (Optional) Storage 2 up to 1x 1TB M.2 SSD (Optional)
<b>Ethernet controller</b>	1 x RJ45-10/100/1000 Mbps LAN
<b>Security</b>	Trusted Platform Module (TPM) 2.0 Kensington Lock
<b>Operating System</b>	Windows 10 IoT Enterprise (64 bit)
<b>WLAN</b>	802.11 a/b/g/n/ac
<b>BT</b>	BT Support
<b>WWAN</b>	4G LTE (Optional)
<b>GNSS</b>	GPS, GLONASS
<b>RFID</b>	HF RFID 13.56 MHz reader (Optional)
<b>Sensors</b>	Light sensor/ g-sensor / Gyro
Camera	
<b>Front Camera</b>	2MP Front Camera
<b>Rear Camera</b>	8MP Rear Camera with auto-focus and LED light
Mechanical	
<b>Dimension</b>	338.2 x 240 x 30 mm (13.3 x 9.4 x 1.18 inches)
<b>Weight</b>	2.4 Kg (Without Kickstand), 2.5 Kg (With Kickstand)
<b>Cooling System</b>	Fanless thermal design
IO Ports	
<b>USB Port</b>	2 x USB 3.0, 2 x USB 2.0, 1 x USB 3.0 (Type C)
<b>Serial Port</b>	1 x RS232 Serial COM Port
<b>SD Card Slot</b>	1 x SDXC Slot
<b>SIM Card Slot</b>	1 x SIM card slot
<b>Video</b>	1 x HDMI
<b>Audio</b>	1 x Headphone Combo Jack Single Digital Mic With Noise Cancellation Dual Speaker
<b>LAN</b>	1 x RJ45-10/100/1000 Mbps LAN
<b>Indicator</b>	4x LED Indicator for Power, Battery, SSD, RF status
<b>Docking Connector</b>	1 x 19-pin docking connector (Optional)

<b>Environment</b>			
<b>Operating Humidity</b>	30% to 80% RH, non-condensing	<b>Operating Temperature</b>	-10°C to 50°C (14°F to 122°F)
<b>Storage Temperature</b>	-20°C to 60°C (-4°F to 140°F)	<b>Shock</b>	MIL-STD-810G Method 516.6 Procedure I
<b>Vibration</b>	MIL-STD-810G Method 514.6 Procedure I	<b>IP rating</b>	IP65 certified, dustproof and waterproof
<b>Drop</b>	MIL-STD-810G Method 516.6, 4 ft		
<b>Certification</b>			
<b>Certification</b>	CE, FCC, IC, UL		
<b>Security Function</b>			
<b>SOTI MobiControl</b>	SOTI MobiControl Compliance	<b>Kensington Lock</b>	Kensington Lock Support
<b>Control</b>			
<b>Button</b>	1 x Power, 1 x menu, 2 x volume key 3 x Programmable Function Keys		
<b>Power</b>			
<b>Battery</b>	7.4V, typ. 10280 mAh Li-Polymer Battery Hot-Swap (Optional)	<b>Battery Operating Time</b>	11 Hours
<b>Power Rating</b>	19V DC	<b>Adapter</b>	100-240V, 50-60Hz / 19V DC
<b>Accessory</b>			
<b>Accessory</b>	Adapter and PowerCord Standard Battery Stylus Stand with Integrated Handle	<b>Optional Accessory</b>	Shoulder Strap (Optional) Battery Charger (Optional) Vehicle Charger (Optional) Desk Docking (Optional) VESA Mounting kit (Optional) VESA Mounting kit2 (Optional)
<b>Barcode Scanner</b>			
<b>Barcode Scanner</b>	1D/2D barcode reader (Optional)		

## DIMENSIONS UNIT:MM

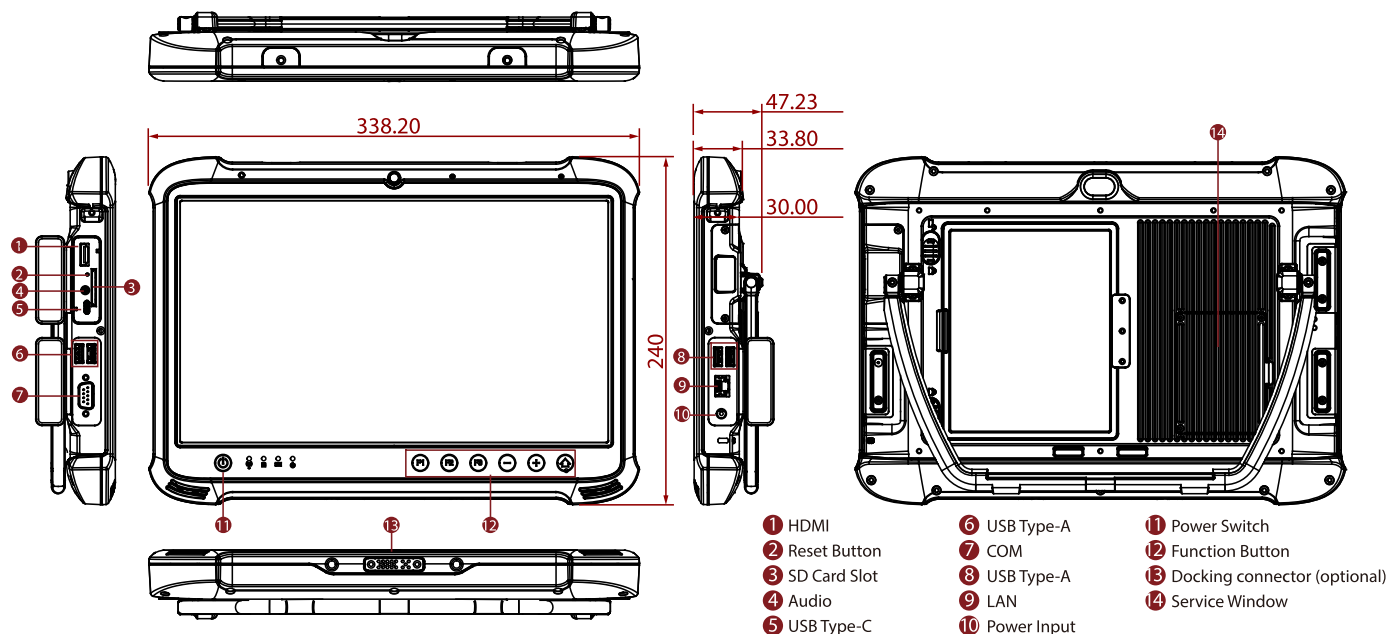

### IP SYSTEMES

8 rue du Colonel Chambonnet – BP67

69672 BRON Cedex

Tel. : 04 72 14 18 00

Fax : 04 72 14 18 01

[www.ip-systemes.com](http://www.ip-systemes.com) – [info@ip-systemes.fr](mailto:info@ip-systemes.fr)

## NOTE

1. Total usable memory will be less dependent upon actual system configuration.
2. Barcode and smart card readers are mutually exclusive options.
4. TPM 2.0 available upon request.
3. The USB Type-C connector follows the USB 3.0 standard, which does not support Alternate Mode (ALT) or USB Power Delivery (USB-PD).
5. Computrace theft protection and SOTI are available upon request.
6. The product shown in this datasheet is a standard model. For diagrams that contain customized or optional I/O, please contact the Winmate Sales Team for more information.
7. Length measurements do not include protrusions. Weight varies with options.
8. Measured at dimming LCD brightness. Varies depending on the usage conditions, or when an external device is attached.
9. Accessories and integrated options may vary depending on your configuration.
10. This is a simplified drawing and some components are not marked in detail.