

APPD 1701T



17" IP65 Industrial 4:3 SXGA LCD Flush Touch Monitor



Main Features

- IP65 compliant plastic front bezel with flush panel by 5-wire touch screen
- Triple display input interface: analog VGA/DVI-D/DisplayPort
- Shares identical appearance with APPC series
- Dual touch screen interface: RS232 and USB
- Ultra slim in depth
- OSD multilanguage function

Product Overview

17" 4:3 LCD display APPD 1701T is based on a 5-wire resistive touch screen. It has 350 nits brightness and can support resolutions up to 1280 x 1024. APPD 1701T is ideal for space-critical environments where systems and displays are kept apart. In addition, APPD 1701T adopts a flush panel design and has IP65 front panel. APPD 1701T provides prevailing video interfaces: VGA, DVI and DisplayPort, supporting both digital and analog signals; touch screen can be connected with RS232 or USB ports. Moreover, APPD 1701T supports 12~24VDC power input and offers panel mount and VESA mount, allowing users to choose the mounting method that meets their situation. APPD 1701T is the best solution for NEXCOM NISE fanless computer, NViS security surveillance series and APPC panel PC when a second display is required.

Specifications

Panel

- LCD size: 17", 4:3
- Resolution: SXGA 1280 x 1024
- Luminance: 350cd/m²
- Contrast ratio: 800
- LCD color: 16.7M
- Viewing angle: 60 (U), 80 (D), 80 (L), 80 (R)
- Backlight: LED

Touch Screen

- 5-Wire resistive (flush panel type)
- Light transmission: 81%
- Interface: USB and RS232

Rear I/O

- Touch interface port: RS232 (1 x DB9)/USB type A
- Video port: VGA (1 x DB15)/DVI-D (1 x DVI-H connector)/DisplayPort
- DC power input connector: 3-pin Phoenix terminal blocks

OSD Function

- OSD keypad
- Multilanguage OSD

Mechanical & Environment

- Color: Pantone black and black silver chassis box
- IP protection: IP65 front
- Mounting: panel/wall/stand/VESA 100mm x 100mm
- Power
 - Power input: 12V~24VDC
 - Power adapter: optional AC to DC power adapter (+12V, 60W)
- Vibration
 - IEC 68 2-64
 - 2Grms @ sine, 5~500Hz, 1hr/axis (operating)
 - 2.2Grms @ random condition, 5~500Hz, 0.5hr/axis (non-operating)
- Shock
 - IEC 68 2-27
 - 20G@wall mount, half sine, 11ms
 - Operating temperature: -5°C~50°C
 - Storage temperature: -20°C~75°C
- Operating humidity: 10%~90% relative humidity, non-condensing
- Dimension: 410.4 x 340.4 x 53.9mm
- Weight: 4.8 kg

Certifications

- CE approval
- FCC Class B

Dimension Drawing

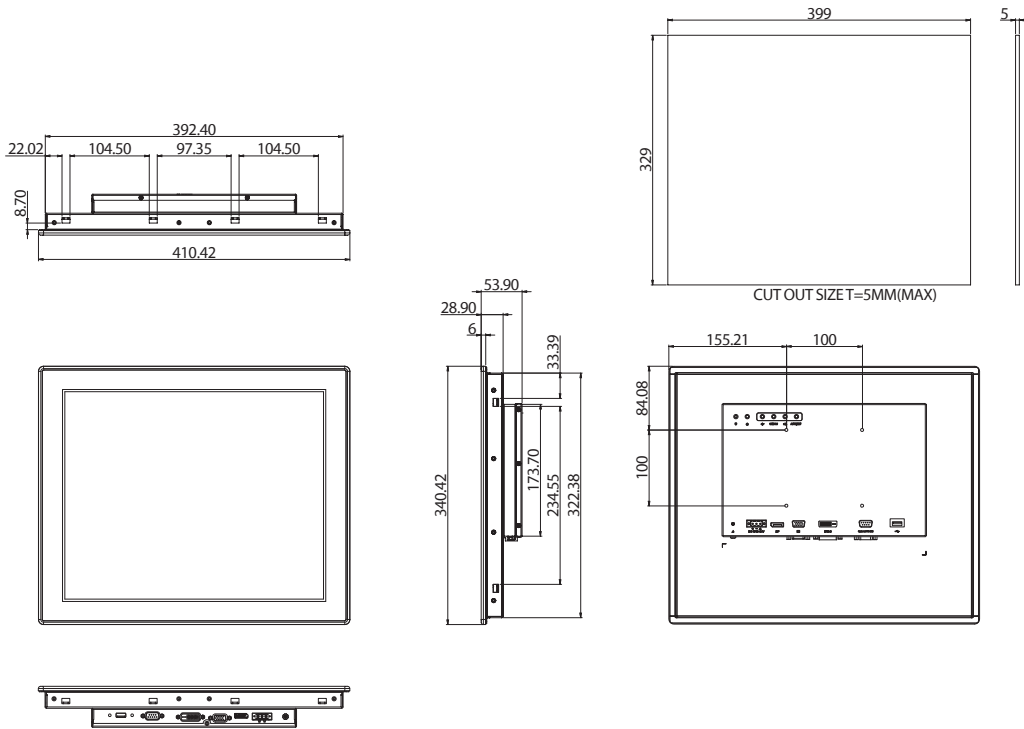

Ordering Information

- ♦ **APPD 1701T (P/N: 10IA1701T00X0)**
17" SXGA industrial 4:3 LCD flush touch monitor with VGA, DVI-D and DisplayPort, 12~24VDC input, RS-232 and USB touch screen

Options

- ♦ **12V, 60W AC/DC power adapter w/o power cord (P/N: 7400060048X00)**
- ♦ **1.8m DVI-D male to DVI-D male cable (P/N: 603DVI0007X00)**



IP SYSTEMES

8 rue du Colonel Chambonnet – BP67

69672 BRON Cedex

Tel. : 04 72 14 18 00

Fax : 04 72 14 18 01

www.ip-systemes.com – info@ip-systemes.fr